

MSP430FR263x, MSP430FR253x Mixed-Signal Microcontrollers

1 Device Overview

1.1 Features

- Embedded Microcontroller
 - 16-Bit RISC Architecture
 - Clock Supports Frequencies up to 16 MHz
 - Wide Supply Voltage Range From 1.8 V to 3.6 V ⁽¹⁾
- Optimized Ultra-Low-Power Modes
 - Active Mode: 126 μ A/MHz (Typical)
 - Standby
 - 1.7 μ A/Button Average (Typical) (16 Self-Capacitance Buttons, 8-Hz Scanning)
 - 1.7 μ A/Button Average (Typical) (64 Mutual-Capacitance Buttons, 8-Hz Scanning)
 - LPM3.5 Real-Time Clock (RTC) Counter With 32768-Hz Crystal: 770 nA (Typical)
 - Shutdown (LPM4.5): 15 nA (Typical)
- Low-Power Ferroelectric RAM (FRAM)
 - Up to 15.5KB of Nonvolatile Memory
 - Built-In Error Correction Code (ECC)
 - Configurable Write Protection
 - Unified Memory of Program, Constants, and Storage
 - 10^{15} Write Cycle Endurance
 - Radiation Resistant and Nonmagnetic
 - High FRAM-to-SRAM Ratio, up to 4:1
- Intelligent Digital Peripherals
 - Four 16-Bit Timers
 - Two Timers With Three Capture/Compare Registers Each (Timer_A3)
 - Two Timers With Two Capture/Compare Registers Each (Timer_A2)
 - One 16-Bit Timer Associated With CapTIvate™ Technology
 - One 16-Bit Counter-Only RTC
 - 16-Bit Cyclic Redundancy Check (CRC)
- Enhanced Serial Communications
 - Two Enhanced Universal Serial Communication Interfaces (eUSCI_A) Support UART, IrDA, and SPI
 - One eUSCI (eUSCI_B) Supports SPI and I²C
- High-Performance Analog
 - 8-Channel 10-Bit Analog-to-Digital Converter (ADC)
 - Internal 1.5-V Reference
 - Sample-and-Hold 200 ksp/s
- [CapTIvate Technology](#) – Capacitive Touch
 - Performance
 - Fast Electrode Scanning With Four Simultaneous Scans
 - Support for High-Resolution Sliders With >1024 Points
 - 30-cm Proximity Sensing
 - Reliability
 - Increased Immunity to Power Line, RF, and Other Environmental Noise
 - Built-in Spread Spectrum, Automatic Tuning, Noise Filtering, and Debouncing Algorithms
 - Enables [Reliable Touch Solutions](#) With 10-V RMS Common-Mode Noise, 4-kV Electrical Fast Transients, and 15-kV Electrostatic Discharge, Allowing for IEC-61000-4-6, IEC-61000-4-4, and IEC-61000-4-2 Compliance
 - Reduced RF Emissions to Simplify Electrical Designs
 - Support for Metal Touch and Water Rejection Designs
 - Flexibility
 - Up to 16 Self-Capacitance and 64 Mutual-Capacitance Electrodes
 - Mix and Match [Self- and Mutual-Capacitive Electrodes in the Same Design](#)
 - Supports Multitouch Functionality
 - Wide Range of Capacitance Detection, Wide Electrode Range of 0 to 300 pF
 - Low Power
 - <0.9 μ A/Button in Wake-on-Touch Mode, Where Capacitive Measurement and Touch Detection is Done by Hardware State Machine While CPU is Asleep
 - Wake-on-Touch State Machine Allows Electrode Scanning While CPU is Asleep
 - Hardware Acceleration for Environmental Compensation, Filtering, and Threshold Detection
 - Ease of Use
 - [CapTIvate Design Center](#), PC GUI Lets Engineers Design and Tune Capacitive Buttons in Real Time Without Having to Write Code

(1) Minimum supply voltage is restricted by SVS levels (see V_{SVSH-} and V_{SVSH+} in [Table 5-2](#))



- CapTIvate Software Library in ROM Provides Ample FRAM for Customer Application
- Clock System (CS)
 - On-Chip 32-kHz RC Oscillator (REFO)
 - On-Chip 16-MHz Digitally Controlled Oscillator (DCO) With Frequency-Locked Loop (FLL)
 - $\pm 1\%$ Accuracy With On-Chip Reference at Room Temperature
 - On-Chip Very Low-Frequency 10-kHz Oscillator (VLO)
 - On-Chip High-Frequency Modulation Oscillator (MODOSC)
 - External 32-kHz Crystal Oscillator (LFXT)
 - Programmable MCLK Prescaler of 1 to 128
 - SMCLK Derived from MCLK With Programmable Prescaler of 1, 2, 4, or 8
- General Input/Output and Pin Functionality
 - Total of 19 I/Os on TSSOP-32 Package
 - 16 Interrupt Pins (P1 and P2) Can Wake MCU From Low-Power Modes
- Development Tools and Software
 - Ease-of-Use Ecosystem
 - CapTIvate Design Center – Code Generation, Customizable GUI, Real-Time Tuning
- Free Professional Development Environments
- 12-KB ROM Library Includes CapTIvate Touch Libraries and Driver Libraries
- Family Members (Also See [Section 3](#))
 - MSP430FR2633: 15KB of Program FRAM + 512B of Information FRAM + 4KB of RAM up to 16 Self-Capacitive and 64 Mutual-Capacitive Sensors
 - MSP430FR2533: 15KB of Program FRAM + 512B of Information FRAM + 2KB of RAM up to 16 Self-Capacitive or 16 Mutual-Capacitive Sensors
 - MSP430FR2632: 8KB of Program FRAM + 512B of Information FRAM + 2KB of RAM up to 8 Self-Capacitive or 16 Mutual-Capacitive Sensors
 - MSP430FR2532: 8KB of Program FRAM + 512B of Information FRAM + 1KB of RAM up to 8 Self-Capacitive or 8 Mutual-Capacitive Sensors
- Package Options
 - 32-Pin: VQFN (RHB)
 - 32-Pin: TSSOP (DA)
 - 24-Pin: VQFN (RGE)
- For Complete Module Descriptions, See the *MSP430FR4xx and MSP430FR2xx Family User's Guide* ([SLAU445](#))

1.2 Applications

- Thermostats
- Electronic Access Control
- Lighting Control
- Electronic Door Locks
- White Goods
- Small Appliances
- Personal Electronics

1.3 Description

The MSP430FR263x and MSP430FR253x are FRAM-based ultra-low-power MSP microcontrollers that feature CapTIvate touch technology for buttons, sliders, wheels (BSW), and proximity applications. CapTIvate technology provides the highest resolution capacitive-touch solution in the market with high reliability and noise immunity at the lowest power. CapTIvate technology supports concurrent self-capacitance and mutual-capacitance electrodes on the same design for maximum flexibility. Using the CapTIvate Design Center, engineers can quickly develop BSW applications with an easy-to-use GUI.

The TI MSP family of low-power microcontrollers consists of several devices that feature different sets of peripherals targeted for various applications. The architecture, combined with extensive low-power modes, is optimized to achieve extended battery life in portable measurement applications. The MCU features a powerful 16-bit RISC CPU, 16-bit registers, and constant generators that contribute to maximum code efficiency. The digitally controlled oscillator (DCO) allows the MCU to wake up from low-power modes to active mode typically in less than 10 μ s.

Device Information⁽¹⁾

PART NUMBER	PACKAGE	BODY SIZE ⁽²⁾
MSP430FR2633IRHB	VQFN (32)	5 mm × 5 mm
MSP430FR2533IRHB	VQFN (32)	5 mm × 5 mm
MSP430FR2633IDA	TSSOP (32)	11 mm × 6.2 mm
MSP430FR2533IDA	TSSOP (32)	11 mm × 6.2 mm
MSP430FR2632IRGE	VQFN (24)	4 mm × 4 mm
MSP430FR2532IRGE	VQFN (24)	4 mm × 4 mm

- (1) For the most current part, package, and ordering information, see the *Package Option Addendum* in [Section 9](#), or see the TI website at www.ti.com.
- (2) The sizes shown here are approximations. For the package dimensions with tolerances, see the *Mechanical Data* in [Section 9](#).

CAUTION

System-level ESD protection must be applied in compliance with the device-level ESD specification to prevent electrical overstress or disturbing of data or code memory. See the application report *MSP430 System-Level ESD Considerations* ([SLAA530](#)) for more information.

1.4 Functional Block Diagram

Figure 1-1 shows the functional block diagram.

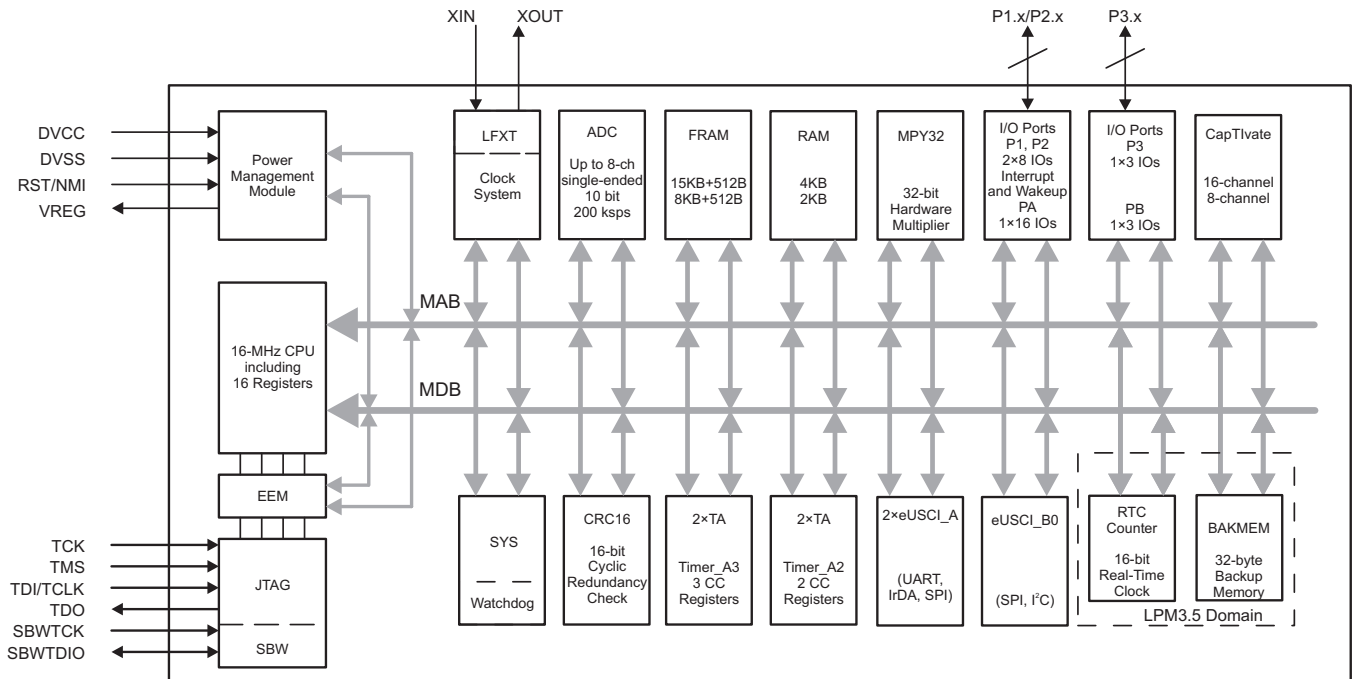

Copyright © 2016, Texas Instruments Incorporated

Figure 1-1. Functional Block Diagram

- The MCU has one main power pair of DVCC and DVSS that supplies digital and analog modules. Recommended bypass and decoupling capacitors are 4.7 μF to 10 μF and 0.1 μF , respectively, with $\pm 5\%$ accuracy.
- VREG is the decoupling capacitor of the CapTIvate regulator. The recommended value for the required decoupling capacitor is 1 μF , with a maximum ESR of $\leq 200 \text{ m}\Omega$.
- P1 and P2 feature the pin interrupt function and can wake the MCU from all LPMs, including LPM3.5 and LPM4.
- Each Timer_A3 has three capture/compare registers. Only CCR1 and CCR2 are externally connected. CCR0 registers can be used only for internal period timing and interrupt generation.
- Each Timer_A2 has two capture/compare registers. Both registers can be used only for internal period timing and interrupt generation.
- In LPM3 mode, the CapTIvate module can be functional while the rest of the peripherals are off.

Table of Contents

1	Device Overview	1	6.1	Overview	43
1.1	Features	1	6.2	CPU	43
1.2	Applications	2	6.3	Operating Modes	43
1.3	Description	2	6.4	Interrupt Vector Addresses	45
1.4	Functional Block Diagram	4	6.5	Bootloader (BSL)	46
2	Revision History	5	6.6	JTAG Standard Interface	47
3	Device Comparison	6	6.7	Spy-Bi-Wire Interface (SBW)	47
4	Terminal Configuration and Functions	7	6.8	FRAM	47
4.1	Pin Diagrams	7	6.9	Memory Protection	47
4.2	Pin Attributes	10	6.10	Peripherals	48
4.3	Signal Descriptions	13	6.11	Input/Output Schematics	58
4.4	Pin Multiplexing	16	6.12	Device Descriptors	65
4.5	Buffer Types	16	6.13	Memory	66
4.6	Connection of Unused Pins	16	6.14	Identification	74
5	Specifications	17	7	Applications, Implementation, and Layout	75
5.1	Absolute Maximum Ratings	17	7.1	Device Connection and Layout Fundamentals	75
5.2	ESD Ratings	17	7.2	Peripheral- and Interface-Specific Design Information	78
5.3	Recommended Operating Conditions	17	7.3	Typical Applications	84
5.4	Active Mode Supply Current Into V _{CC} Excluding External Current	18	8	Device and Documentation Support	85
5.5	Active Mode Supply Current Per MHz	18	8.1	Device Support	85
5.6	Low-Power Mode LPM0 Supply Currents Into V _{CC} Excluding External Current	18	8.2	Documentation Support	88
5.7	Low-Power Mode LPM3 Supply Currents (Into V _{CC}) Excluding External Current	19	8.3	Related Links	89
5.8	Low-Power Mode LPMx.5 Supply Currents (Into V _{CC}) Excluding External Current	20	8.4	Community Resources	89
5.9	Typical Characteristics - Low-Power Mode Supply Currents	21	8.5	Trademarks	89
5.10	Thermal Resistance Characteristics	23	8.6	Electrostatic Discharge Caution	89
5.11	Timing and Switching Characteristics	24	8.7	Export Control Notice	89
6	Detailed Description	43	8.8	Glossary	89
			9	Mechanical, Packaging, and Orderable Information	90

2 Revision History

NOTE: Page numbers for previous revisions may differ from page numbers in the current version.

Changes from November 10, 2015 to December 8, 2015	Page
• Changed document status from Preview to Production Data	1
• Added note to list item that starts "Wide Supply Voltage Range..."	1
• Changed list item that starts "Enables Reliable Touch Solutions..."	1
• In the note that starts "Low-power mode 3, VLO, excludes SVS test conditions...", changed "f _{XT1} = 0 Hz" to "f _{XT1} = 32768 Hz"	19
• Added note that starts "The VLO clock frequency is reduced by 15%..."	28
• Added note to "Clock" in Table 6-1, Operating Modes	44
• Added note that starts "XT1CLK and VLOCLK can be active during LPM4..."	44
• Corrected description in Section 6.10.10, Backup Memory (BKMEM)	55

3 Device Comparison

Table 3-1 summarizes the features of the available family members.

Table 3-1. Device Comparison⁽¹⁾⁽²⁾

DEVICE	PROGRAM FRAM + INFORMATION FRAM (bytes)	SRAM (bytes)	TA0 TO TA3	eUSCI_A		eUSCI_B	10-BIT ADC CHANNELS	CapTIvate™ CHANNELS	GPIOs	PACKAGE TYPE
				UART	SPI					
MSP430FR2633IRHB	15360 + 512	4096	2, 3 × CCR ⁽³⁾ 2, 2 × CCR	up to 2	up to 2	1	8	16 ⁽⁴⁾	19	32 RHB (VQFN)
MSP430FR2533IRHB	15360 + 512	2048	2, 3 × CCR ⁽³⁾ 2, 2 × CCR	up to 2	up to 2	1	8	16 ⁽⁴⁾	19	32 RHB (VQFN)
MSP430FR2633IDA	15360 + 512	4096	2, 3 × CCR ⁽³⁾ 2, 2 × CCR	up to 2	up to 2	1	8	16 ⁽⁴⁾	19	32 DA (TSSOP)
MSP430FR2533IDA	15360 + 512	2048	2, 3 × CCR ⁽³⁾ 2, 2 × CCR	up to 2	up to 2	1	8	16 ⁽⁴⁾	19	32 DA (TSSOP)
MSP430FR2632IRGE	8192 + 512	2048	2, 3 × CCR ⁽³⁾ 2, 2 × CCR	up to 2	1	1	8	8 ⁽⁵⁾	15	24 RGE (VQFN)
MSP430FR2532IRGE	8192 + 512	1,024	2, 3 × CCR ⁽³⁾ 2, 2 × CCR	up to 2	1	1	8	8 ⁽⁵⁾	15	24 RGE (VQFN)

- (1) For the most current package and ordering information, see the *Package Option Addendum* in [Section 9](#), or see the TI website at www.ti.com
- (2) Package drawings, standard packing quantities, thermal data, symbolization, and PCB design guidelines are available at www.ti.com/packaging
- (3) A CCR register is a configurable register that provides internal and external capture or compare inputs, or internal and external PWM outputs.
- (4) Eight dedicated CapTIvate channels are included.
- (5) Four dedicated CapTIvate channels are included.

4 Terminal Configuration and Functions

4.1 Pin Diagrams

Figure 4-1 shows the pinout for the 24-pin RHB package.

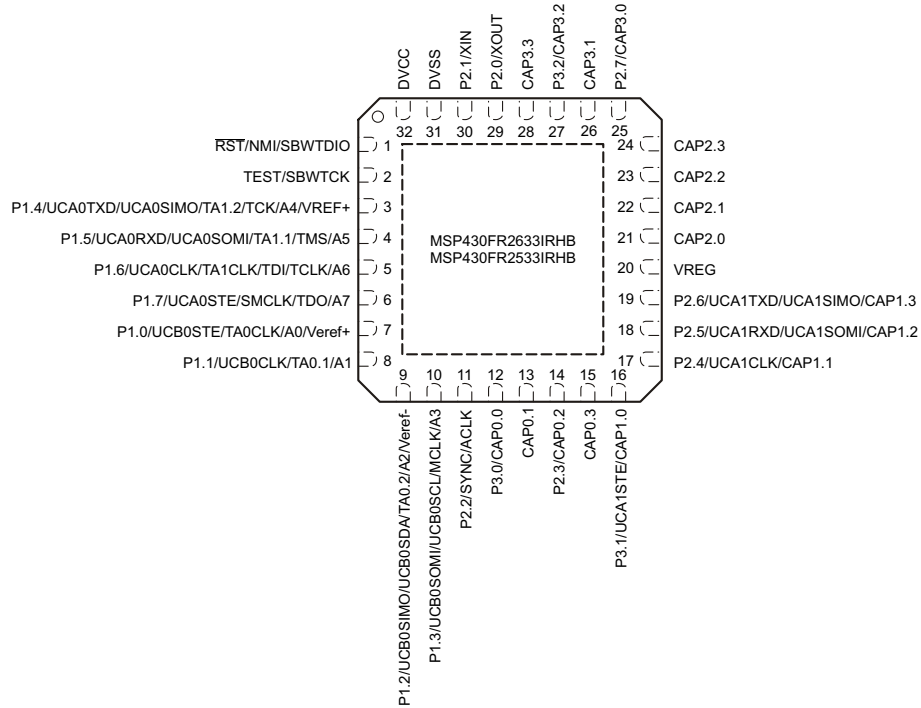

Figure 4-1. 32-Pin RHB Package (Top View)

Figure 4-2 shows the pinout for the 32-pin DA package.

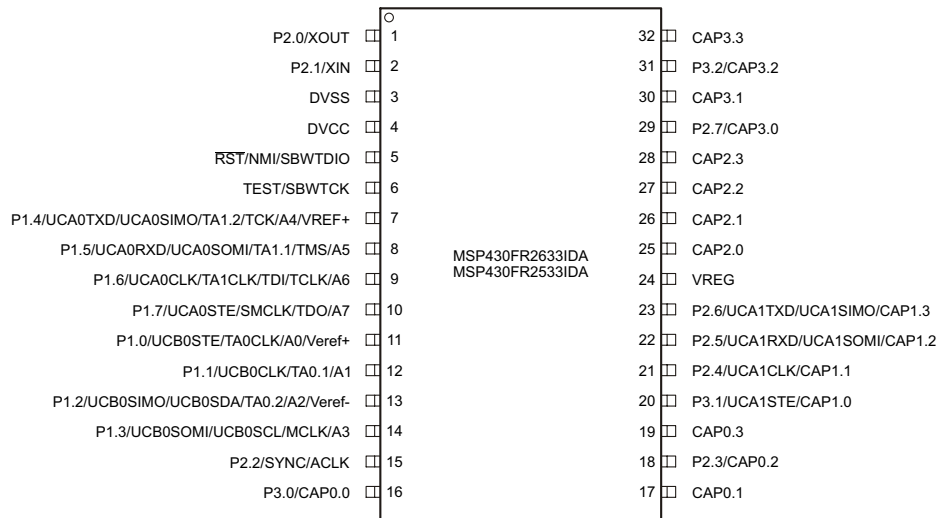

Figure 4-2. 32-Pin DA Package (Top View)

Figure 4-3 shows the pinout for the 24-pin RGE package.

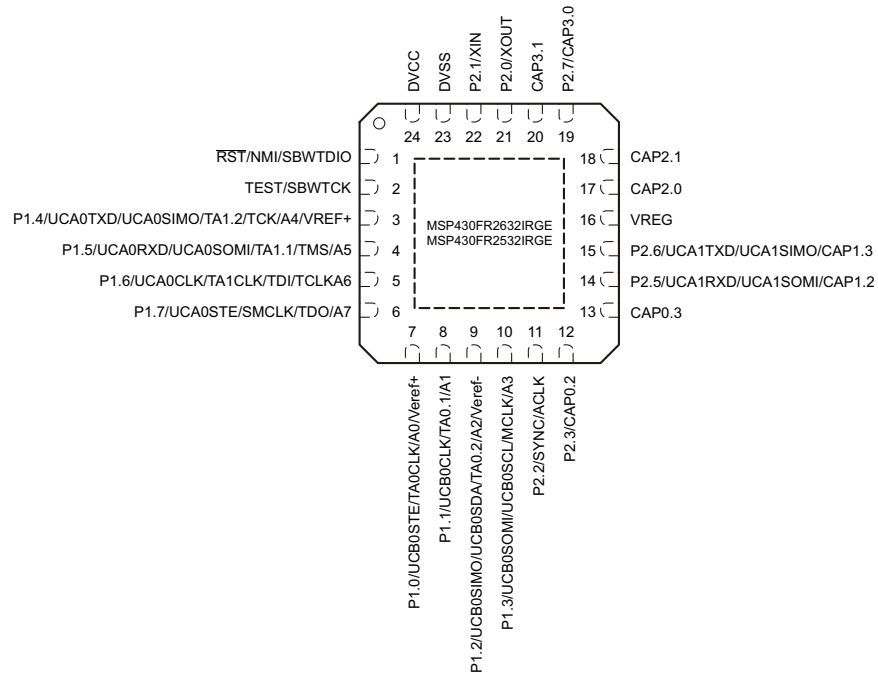

Figure 4-3. 24-Pin RGE Package (Top View)

4.2 Pin Attributes

Table 4-1 lists the attributes of all pins.

Table 4-1. Pin Attributes

PIN NUMBER			SIGNAL NAME ^{(1) (2)}	SIGNAL TYPE ⁽³⁾	BUFFER TYPE ⁽⁴⁾	POWER SOURCE ⁽⁵⁾	RESET STATE AFTER BOR ⁽⁶⁾
RHB	DA	RGE					
1	5	1	RST (RD)	I	LVC MOS	DVCC	OFF
			NMI	I	LVC MOS	DVCC	–
			SBWTDIO	I/O	LVC MOS	DVCC	–
2	6	2	TEST (RD)	I	LVC MOS	DVCC	OFF
			SBWTCK	I	LVC MOS	DVCC	–
3	7	3	P1.4 (RD)	I/O	LVC MOS	DVCC	OFF
			UCA0TXD	O	LVC MOS	DVCC	–
			UCA0SIMO	I/O	LVC MOS	DVCC	–
			TA1.2	I/O	LVC MOS	DVCC	–
			TCK	I	LVC MOS	DVCC	–
			A4	I	Analog	DVCC	–
			VREF+	O	Power	DVCC	–
4	8	4	P1.5 (RD)	I/O	LVC MOS	DVCC	OFF
			UCA0RXD	I	LVC MOS	DVCC	–
			UCA0SOMI	I/O	LVC MOS	DVCC	–
			TA1.1	I/O	LVC MOS	DVCC	–
			TMS	I	LVC MOS	DVCC	–
			A5	I	Analog	DVCC	–
5	9	5	P1.6 (RD)	I/O	LVC MOS	DVCC	OFF
			UCA0CLK	I/O	LVC MOS	DVCC	–
			TA1CLK	I	LVC MOS	DVCC	–
			TDI	I	LVC MOS	DVCC	–
			TCLK	I	LVC MOS	DVCC	–
			A6	I	Analog	DVCC	–
6	10	6	P1.7 (RD)	I/O	LVC MOS	DVCC	OFF
			UCA0STE	I/O	LVC MOS	DVCC	–
			SMCLK	O	LVC MOS	DVCC	–
			TDO	O	LVC MOS	DVCC	–
			A7	I	Analog	DVCC	–
7	11	7	P1.0 (RD)	I/O	LVC MOS	DVCC	OFF
			UCB0STE	I/O	LVC MOS	DVCC	–
			TA0CLK	I	LVC MOS	DVCC	–
			A0	I	Analog	DVCC	–
			Veref+	I	Power	DVCC	–

(1) Signals names with (RD) denote the reset default pin name.

(2) To determine the pin mux encodings for each pin, see Section 6.11, *Input/Output Schematics*.

(3) Signal Types: I = Input, O = Output, I/O = Input or Output

(4) Buffer Types: LVC MOS, Analog, or Power (see Table 4-3)

(5) The power source shown in this table is the I/O power source, which may differ from the module power source.

(6) Reset States:

OFF = High-impedance with Schmitt trigger and pullup or pulldown (if available) disabled

N/A = Not applicable

Table 4-1. Pin Attributes (continued)

PIN NUMBER			SIGNAL NAME ^{(1) (2)}	SIGNAL TYPE ⁽³⁾	BUFFER TYPE ⁽⁴⁾	POWER SOURCE ⁽⁵⁾	RESET STATE AFTER BOR ⁽⁶⁾
RHB	DA	RGE					
8	12	8	P1.1 (RD)	I/O	LVC MOS	DVCC	OFF
			UCB0CLK	I/O	LVC MOS	DVCC	–
			TA0.1	I/O	LVC MOS	DVCC	–
			A1	I	Analog	DVCC	–
9	13	9	P1.2 (RD)	I/O	LVC MOS	DVCC	OFF
			UCB0SIMO	I/O	LVC MOS	DVCC	–
			UCB0SDA	I/O	LVC MOS	DVCC	–
			TA0.2	I/O	LVC MOS	DVCC	–
			A2	I	Analog	DVCC	–
			Veref-	I	Power	DVCC	–
10	14	10	P1.3 (RD)	I/O	LVC MOS	DVCC	OFF
			UCB0SOMI	I/O	LVC MOS	DVCC	–
			UCB0SCL	I/O	LVC MOS	DVCC	–
			MCLK	O	LVC MOS	DVCC	–
			A3	I	Analog	DVCC	–
11	15	11	P2.2 (RD)	I/O	LVC MOS	DVCC	OFF
			SYNC	I	LVC MOS	DVCC	–
			ACLK	I/O	LVC MOS	DVCC	–
12	16		P3.0 (RD)	I/O	LVC MOS	DVCC	OFF
			CAP0.0	I/O	Analog	V _{REG}	–
13	17		CAP0.1	I/O	Analog	V _{REG}	OFF
14	18	12	P2.3 (RD)	I/O	LVC MOS	DVCC	OFF
			CAP0.2	I/O	Analog	V _{REG}	–
15	19	13	CAP0.3	I/O	Analog	V _{REG}	OFF
16	20		P3.1 (RD)	I/O	LVC MOS	DVCC	OFF
			UCA1STE	I/O	LVC MOS	DVCC	–
			CAP1.0	I/O	Analog	V _{REG}	–
17	21		P2.4 (RD)	I/O	LVC MOS	DVCC	OFF
			UCA1CLK	I/O	LVC MOS	DVCC	–
			CAP1.1	I/O	Analog	V _{REG}	–
18	22	14	P2.5 (RD)	I/O	LVC MOS	DVCC	OFF
			UCA1RXD	I	LVC MOS	DVCC	–
			UCA1SOMI	I/O	LVC MOS	DVCC	–
			CAP1.2	I/O	Analog	V _{REG}	–
19	23	15	P2.6 (RD)	I/O	LVC MOS	DVCC	OFF
			UCA1TXD	O	LVC MOS	DVCC	–
			UCA1SIMO	I/O	LVC MOS	DVCC	–
			CAP1.3	I/O	Analog	V _{REG}	–
20	24	16	VREG	P	Power	V _{REG}	N/A
21	25	17	CAP2.0	I/O	Analog	V _{REG}	OFF
22	26	18	CAP2.1	I/O	Analog	V _{REG}	OFF
23	27		CAP2.2	I/O	Analog	V _{REG}	OFF
24	28		CAP2.3	I/O	Analog	V _{REG}	OFF
25	29	19	P2.7 (RD)	I/O	LVC MOS	DVCC	OFF
			CAP3.0	I/O	Analog	V _{REG}	–
26	30	20	CAP3.1	I/O	Analog	V _{REG}	OFF

Table 4-1. Pin Attributes (continued)

PIN NUMBER			SIGNAL NAME ⁽¹⁾ (2)	SIGNAL TYPE ⁽³⁾	BUFFER TYPE ⁽⁴⁾	POWER SOURCE ⁽⁵⁾	RESET STATE AFTER BOR ⁽⁶⁾
RHB	DA	RGE					
27	31		P3.2 (RD)	I/O	LVC MOS	DVCC	OFF
			CAP3.2	I/O	Analog	V _{REG}	–
28	32		CAP3.3	I/O	Analog	V _{REG}	OFF
29	1	21	P2.0 (RD)	I/O	LVC MOS	DVCC	OFF
			XOUT	O	LVC MOS	DVCC	–
30	2	22	P2.1 (RD)	I/O	LVC MOS	DVCC	OFF
			XIN	I	LVC MOS	DVCC	–
31	3	23	DVSS	P	Power	DVCC	N/A
32	4	24	DVCC	P	Power	DVCC	N/A

4.3 Signal Descriptions

Table 4-2 describes the signals for all device variants and package options.

Table 4-2. Signal Descriptions

FUNCTION	SIGNAL NAME	PIN NUMBER			PIN TYPE ⁽¹⁾	DESCRIPTION
		RHB	DA	RGE		
ADC	A0	7	11	7	I	Analog input A0
	A1	8	12	8	I	Analog input A1
	A2	9	13	9	I	Analog input A2
	A3	10	14	10	I	Analog input A3
	A4	3	7	3	I	Analog input A4
	A5	4	8	4	I	Analog input A5
	A6	5	9	5	I	Analog input A6
	A7	6	10	6	I	Analog input A7
	Veref+	7	11	7	I	ADC positive reference
Veref-	9	13	9	I	ADC negative reference	
CapTlvate	CAP0.0	12	16		I/O	CapTlvate channel
	CAP0.1	13	17		I/O	CapTlvate channel
	CAP0.2	14	18	12	I/O	CapTlvate channel
	CAP0.3	15	19	13	I/O	CapTlvate channel
	CAP1.0	16	20		I/O	CapTlvate channel
	CAP1.1	17	21		I/O	CapTlvate channel
	CAP1.2	18	22	14	I/O	CapTlvate channel
	CAP1.3	19	23	15	I/O	CapTlvate channel
	CAP2.0	21	25	17	I/O	CapTlvate channel
	CAP2.1	22	26	18	I/O	CapTlvate channel
	CAP2.2	23	27		I/O	CapTlvate channel
	CAP2.3	24	28		I/O	CapTlvate channel
	CAP3.0	25	29	19	I/O	CapTlvate channel
	CAP3.1	26	30	20	I/O	CapTlvate channel
	CAP3.2	27	31		I/O	CapTlvate channel
	CAP3.3	28	32		I/O	CapTlvate channel
SYNC	11	15	11	I	CapTlvate synchronous trigger input for processing and conversion	
Clock	ACLK	11	15	11	I/O	ACLK output
	MCLK	10	14	10	O	MCLK output
	SMCLK	6	10	6	O	SMCLK output
	XIN	30	2	22	I	Input terminal for crystal oscillator
	XOUT	29	1	21	O	Output terminal for crystal oscillator
Debug	SBWTCK	2	6	2	I	Spy-Bi-Wire input clock
	SBWTDIO	1	5	1	I/O	Spy-Bi-Wire data input/output
	TCK	3	7	3	I	Test clock
	TCLK	5	9	5	I	Test clock input
	TDI	5	9	5	I	Test data input
	TDO	6	10	6	O	Test data output
	TEST	2	6	2	I	Test Mode pin – selected digital I/O on JTAG pins
TMS	4	8	4	I	Test mode select	

(1) Pin Types: I = Input, O = Output, I/O = Input or Output, P = Power

Table 4-2. Signal Descriptions (continued)

FUNCTION	SIGNAL NAME	PIN NUMBER			PIN TYPE ⁽¹⁾	DESCRIPTION
		RHB	DA	RGE		
GPIO	P1.0	7	11	7	I/O	General-purpose I/O
	P1.1	8	12	8	I/O	General-purpose I/O
	P1.2	9	13	9	I/O	General-purpose I/O
	P1.3	10	14	10	I/O	General-purpose I/O
	P1.4	3	7	3	I/O	General-purpose I/O ⁽²⁾
	P1.5	4	8	4	I/O	General-purpose I/O ⁽²⁾
	P1.6	5	9	5	I/O	General-purpose I/O ⁽²⁾
	P1.7	6	10	6	I/O	General-purpose I/O ⁽²⁾
	P2.0	29	1	21	I/O	General-purpose I/O
	P2.1	30	2	22	I/O	General-purpose I/O
	P2.2	11	15	11	I/O	General-purpose I/O
	P2.3	14	18	12	I/O	General-purpose I/O
	P2.4	17	21		I/O	General-purpose I/O
	P2.5	18	22	14	I/O	General-purpose I/O
	P2.6	19	23	15	I/O	General-purpose I/O
	P2.7	25	29	19	I/O	General-purpose I/O
	P3.0	12	16		I/O	General-purpose I/O
	P3.1	16	20		I/O	General-purpose I/O
P3.2	27	31		I/O	General-purpose I/O	
I ² C	UCB0SCL	10	14	10	I/O	eUSCI_B0 I ² C clock
	UCB0SDA	9	13	9	I/O	eUSCI_B0 I ² C data
Power	DVCC	32	4	24	P	Power supply
	DVSS	31	3	23	P	Power ground
	VREF+	3	7	3	P	Output of positive reference voltage with ground as reference
	VREG	20	24	16	O	CapTIvate regulator external decoupling capacitor
SPI	UCA0CLK	5	9	5	I/O	eUSCI_A0 SPI clock input/output
	UCA0SIMO	3	7	3	I/O	eUSCI_A0 SPI slave in/master out
	UCA0SOMI	4	8	4	I/O	eUSCI_A0 SPI slave out/master in
	UCA0STE	6	10	6	I/O	eUSCI_A0 SPI slave transmit enable
	UCA1CLK	17	21		I/O	eUSCI_A1 SPI clock input/output
	UCA1SIMO	19	23	15	I/O	eUSCI_A1 SPI slave in/master out
	UCA1SOMI	18	22	14	I/O	eUSCI_A1 SPI slave out/master in
	UCA1STE	16	20		I/O	eUSCI_A1 SPI slave transmit enable
	UCB0CLK	8	12	8	I/O	eUSCI_B0 clock input/output
	UCB0SIMO	9	13	9	I/O	eUSCI_B0 SPI slave in/master out
	UCB0SOMI	10	14	10	I/O	eUSCI_B0 SPI slave out/master in
UCB0STE	7	11	7	I/O	eUSCI_B0 slave transmit enable	
System	NMI	1	5	1	I	Nonmaskable interrupt input
	RST	1	5	1	I	Active-low reset input

(2) Because this pin is multiplexed with the JTAG function, TI recommends disabling the pin interrupt function while in JTAG debug to prevent collisions.

Table 4-2. Signal Descriptions (continued)

FUNCTION	SIGNAL NAME	PIN NUMBER			PIN TYPE ⁽¹⁾	DESCRIPTION
		RHB	DA	RGE		
Timer_A	TA0.1	8	12	8	I/O	Timer TA0 CCR1 capture: CCI1A input, compare: Out1 outputs
	TA0.2	9	13	9	I/O	Timer TA0 CCR2 capture: CCI2A input, compare: Out2 outputs
	TA0CLK	7	11	7	I	Timer clock input TACLK for TA0
	TA1.1	4	8	4	I/O	Timer TA1 CCR1 capture: CCI1A input, compare: Out1 outputs
	TA1.2	3	7	3	I/O	Timer TA1 CCR2 capture: CCI2A input, compare: Out2 outputs
	TA1CLK	5	9	5	I	Timer clock input TACLK for TA1
UART	UCA0RXD	4	8	4	I	eUSCI_A0 UART receive data
	UCA0TXD	3	7	3	O	eUSCI_A0 UART transmit data
	UCA1RXD	18	22	14	I	eUSCI_A1 UART receive data
	UCA1TXD	19	23	15	O	eUSCI_A1 UART transmit data

4.4 Pin Multiplexing

Pin multiplexing for these MCUs is controlled by both register settings and operating modes (for example, if the MCU is in test mode). For details of the settings for each pin and schematics of the multiplexed ports, see [Section 6.11](#).

4.5 Buffer Types

[Table 4-3](#) defines the pin buffer types that are listed in [Table 4-1](#).

Table 4-3. Buffer Types

BUFFER TYPE (STANDARD)	NOMINAL VOLTAGE	HYSTERESIS	PU OR PD	NOMINAL PU OR PD STRENGTH (μ A)	OUTPUT DRIVE STRENGTH (mA)	OTHER CHARACTERISTICS
LVC MOS	3.0 V	Υ ⁽¹⁾	Programmable	See Section 5.11.4	See Section 5.11.4	
Analog	3.0 V	N	N/A	N/A	N/A	See analog modules in Section 5 for details.
Power (DVCC)	3.0 V	N	N/A	N/A	N/A	SVS enables hysteresis on DVCC.
Power (AVCC)	3.0 V	N	N/A	N/A	N/A	

(1) Only for input pins.

4.6 Connection of Unused Pins

[Table 4-4](#) lists the correct termination of unused pins.

Table 4-4. Connection of Unused Pins⁽¹⁾

PIN	POTENTIAL	COMMENT
Px.0 to Px.7	Open	Switched to port function, output direction (PxDIR.n = 1)
$\overline{\text{RST}}/\text{NMI}$	DV _{CC}	47-k Ω pullup or internal pullup selected with 10-nF (or 1.1-nF) pulldown ⁽²⁾
TEST	Open	This pin always has an internal pulldown enabled.
CAP2.x, CAPx.1, CAPx.3	Open	These pins have internal pullup and pulldown resistors, and high impedance is their default setting.

(1) Any unused pin with a secondary function that is shared with general-purpose I/O should follow the Px.0 to Px.7 unused pin connection guidelines.

(2) The pulldown capacitor should not exceed 1.1 nF when using MCUs with Spy-Bi-Wire interface in Spy-Bi-Wire mode with TI tools like FET interfaces or GANG programmers.

5 Specifications

5.1 Absolute Maximum Ratings⁽¹⁾

over operating free-air temperature range (unless otherwise noted)

	MIN	MAX	UNIT
Voltage applied at DVCC pin to V _{SS}	-0.3	4.1	V
Voltage applied to any dedicated CapTIvate pin or pin in CapTIvate mode ⁽²⁾	-0.3	V _{REG}	V
Voltage applied to any other pin ⁽³⁾	-0.3	V _{CC} + 0.3 (4.1 V Max)	V
Diode current at any device pin		±2	mA
Maximum junction temperature, T _J		85	°C
Storage temperature, T _{stg} ⁽⁴⁾⁽⁵⁾	-40	125	°C

- Stresses beyond those listed under *Absolute Maximum Ratings* may cause permanent damage to the device. These are stress ratings only, and functional operation of the device at these or any other conditions beyond those indicated under *Recommended Operating Conditions* is not implied. Exposure to absolute-maximum-rated conditions for extended periods may affect device reliability.
- This applies to dedicated CapTIvate I/Os only or I/Os worked in CapTIvate mode.
- All voltages referenced to V_{SS}.
- Higher temperature may be applied during board soldering according to the current JEDEC J-STD-020 specification with peak reflow temperatures not higher than classified on the device label on the shipping boxes or reels.
- Data retention on FRAM cannot be ensured when exceeding the specified maximum storage temperature, T_{stg}. Therefore, programming of devices with user application code should only be performed after soldering.

5.2 ESD Ratings

		VALUE	UNIT
V _(ESD)	Electrostatic discharge	Human-body model (HBM), per ANSI/ESDA/JEDEC JS-001 ⁽¹⁾	±2000
		Charged-device model (CDM), per JEDEC specification JESD22-C101 ⁽²⁾	±500

- JEDEC document JEP155 states that 500-V HBM allows safe manufacturing with a standard ESD control process. Pins listed as ±2000 V may actually have higher performance.
- JEDEC document JEP157 states that 250-V CDM allows safe manufacturing with a standard ESD control process. Pins listed as ±500 V may actually have higher performance.

5.3 Recommended Operating Conditions

		MIN	NOM	MAX	UNIT
V _{CC}	Supply voltage applied at DVCC pin ⁽¹⁾⁽²⁾⁽³⁾	1.8		3.6	V
V _{SS}	Supply voltage applied at DVSS pin		0		V
T _A	Operating free-air temperature	-40		85	°C
T _J	Operating junction temperature	-40		85	°C
C _{DVCC}	Recommended capacitor at DVCC ⁽⁴⁾	4.7	10		µF
C _{REG}	External buffer capacitor, ESR ≤ 200 mΩ	0.8	1	1.2	µF
C _{ELECTRODE}	Maximum capacitance of all external electrodes on all CapTIvate blocks			300	pF
f _{SYSTEM}	Processor frequency (maximum MCLK frequency) ⁽³⁾⁽⁵⁾	No FRAM wait states (NWAITS _x = 0)	0	8	MHz
		With FRAM wait states (NWAITS _x = 1) ⁽⁶⁾	0	16 ⁽⁷⁾	
f _{ACLK}	Maximum ACLK frequency			40	kHz
f _{SMCLK}	Maximum SMCLK frequency			16 ⁽⁷⁾	MHz

- Supply voltage changes faster than 0.2 V/µs can trigger a BOR reset even within the recommended supply voltage range.
- Modules may have a different supply voltage range specification. See the specification of the respective module in this data sheet.
- The minimum supply voltage is defined by the SVS levels. Refer to the SVS threshold parameters in [Table 5-2](#).
- A capacitor tolerance of ±20% or better is required.
- Modules may have a different maximum input clock specification. See the specification of the respective module in this data sheet.
- Wait states only occur on actual FRAM accesses (that is, on FRAM cache misses). RAM and peripheral accesses are always executed without wait states.
- If clock sources such as HF crystals or the DCO with frequencies >16 MHz are used, the clock must be divided in the clock system to comply with this operating condition.

5.4 Active Mode Supply Current Into V_{CC} Excluding External Current

See ⁽¹⁾

PARAMETER	EXECUTION MEMORY	TEST CONDITION	FREQUENCY ($f_{MCLK} = f_{SMCLK}$)						UNIT
			1 MHz 0 WAIT STATES (NWAITS _x = 0)		8 MHz 0 WAIT STATES (NWAITS _x = 0)		16 MHz 1 WAIT STATE (NWAITS _x = 1)		
			TYP	MAX	TYP	MAX	TYP	MAX	
$I_{AM, FRAM(0\%)}$	FRAM 0% cache hit ratio	3 V, 25°C	504		2772		3047	3480	μA
		3 V, 85°C	516		2491		2871		
$I_{AM, FRAM(100\%)}$	FRAM 100% cache hit ratio	3 V, 25°C	203		625		1000	1215	μA
		3 V, 85°C	212		639		1016		
$I_{AM, RAM}^{(2)}$	RAM	3 V, 25°C	229		818		1377		μA

(1) All inputs are tied to 0 V or to V_{CC} . Outputs do not source or sink any current. Characterized with program executing typical data processing.

$f_{ACLK} = 32768$ Hz, $f_{MCLK} = f_{SMCLK} = f_{DCO}$ at specified frequency

Program and data entirely reside in FRAM. All execution is from FRAM.

(2) Program and data reside entirely in RAM. All execution is from RAM. No access to FRAM.

5.5 Active Mode Supply Current Per MHz

 $V_{CC} = 3$ V, $T_A = 25^\circ C$ (unless otherwise noted)

PARAMETER	TEST CONDITIONS	TYP	UNIT
$dI_{AM,FRAM}/df$	Active mode current consumption per MHz, execution from FRAM, no wait states	I_{AM} (75% cache hit rate) at 8 MHz – I_{AM} (75% cache hit rate) at 1 MHz / 7 MHz	126 $\mu A/MHz$

5.6 Low-Power Mode LPM0 Supply Currents Into V_{CC} Excluding External Current

 $V_{CC} = 3$ V, $T_A = 25^\circ C$ (unless otherwise noted)⁽¹⁾⁽²⁾

PARAMETER	V_{CC}	FREQUENCY (f_{SMCLK})						UNIT
		1 MHz		8 MHz		16 MHz		
		TYP	MAX	TYP	MAX	TYP	MAX	
I_{LPM0}	2 V	156		328		420		μA
	3 V	166		342		433		

(1) All inputs are tied to 0 V or to V_{CC} . Outputs do not source or sink any current.

(2) Current for watchdog timer clocked by SMCLK included.

$f_{ACLK} = 32768$ Hz, $f_{MCLK} = 0$ MHz, f_{SMCLK} at specified frequency.

5.7 Low-Power Mode LPM3 Supply Currents (Into V_{CC}) Excluding External Current

 over recommended ranges of supply voltage and operating free-air temperature (unless otherwise noted) ⁽¹⁾

PARAMETER	V_{CC}	-40°C		25°C		85°C		UNIT
		TYP	MAX	TYP	MAX	TYP	MAX	
$I_{LPM3,XT1}$ Low-power mode 3, 12.5-pF crystal, includes SVS ⁽²⁾⁽³⁾⁽⁴⁾	3 V	0.98		1.18	1.65	3.24		μA
	2 V	0.96		1.16		3.21		
$I_{LPM3,VLO}$ Low-power mode 3, VLO, excludes SVS ⁽⁵⁾	3 V	0.78		0.98	1.40	3.04		μA
	2 V	0.76		0.96		3.01		
$I_{LPM3,RTC}$ Low-power mode 3, RTC, excludes SVS ⁽⁶⁾	3 V	0.93		1.13		3.19		μA
$I_{LPM3, CapTlvate, 1 proximity, wake on touch}$ Low-power mode 3, CapTlvate, excludes SVS ⁽⁷⁾	3.3 V			5				μA
$I_{LPM3, CapTlvate, 1 button, wake on touch}$ Low-power mode 3, CapTlvate, excludes SVS ⁽⁸⁾	3.3 V			3.4				μA
$I_{LPM3, CapTlvate, 4 button, wake on touch}$ Low-power mode 3, CapTlvate, excludes SVS ⁽⁹⁾	3.3 V			3.6				μA
$I_{LPM3, CapTlvate, 16 button}$ Low-power mode 3, CapTlvate, excludes SVS ⁽¹⁰⁾	3.3 V			27.2				μA
$I_{LPM3, CapTlvate, 64 button}$ Low-power mode 3, CapTlvate, excludes SVS ⁽¹¹⁾	3.3 V			109.2				μA
$I_{LPM4,SVS}$ Low-power mode 4, includes SVS	3 V	0.51		0.65		2.65		μA
	2 V	0.49		0.64		2.63		
I_{LPM4} Low-power mode 4, excludes SVS	3 V	0.35		0.49		2.49		μA
	2 V	0.34		0.48		2.46		

(1) All inputs are tied to 0 V or to VCC. Outputs do not source or sink any current.

(2) Not applicable for MCUs with HF crystal oscillator only.

(3) Characterized with a Micro Crystal MS1V-T1K crystal with a load capacitance of 12.5 pF. The internal and external load capacitance are chosen to closely match the required 12.5-pF load.

(4) Low-power mode 3, 12.5-pF crystal, includes SVS test conditions:

Current for watchdog timer clocked by ACLK and RTC clocked by XT1 included. Current for brownout and SVS included (SVSHE = 1). CPUOFF = 1, SCG0 = 1 SCG1 = 1, OSCOFF = 0 (LPM3),

$f_{XT1} = 32768$ Hz, $f_{ACLK} = f_{XT1}$, $f_{MCLK} = f_{SMCLK} = 0$ MHz

(5) Low-power mode 3, VLO, excludes SVS test conditions:

Current for watchdog timer clocked by VLO included. RTC disabled. Current for brownout included. SVS disabled (SVSHE = 0).

CPUOFF = 1, SCG0 = 1 SCG1 = 1, OSCOFF = 0 (LPM3)

$f_{XT1} = 32768$ Hz, $f_{ACLK} = f_{MCLK} = f_{SMCLK} = 0$ MHz

(6) RTC periodically wakes up every second with external 32768-Hz input as source.

(7) CapTlvate technology works in LPM3 with one proximity sensor for wake on touch. CapTlvate BSWP demo panel with 1.5-mm overlay.

Current for brownout included. SVS disabled (SVSHE = 0).

$f_{SCAN} = 8$ Hz, $f_{CONVER} = 2$ MHz, COUNTS = 800

(8) CapTlvate technology works in LPM3 with one button, wake on touch. CapTlvate BSWP demo panel with 1.5-mm overlay, Current for brownout included. SVS disabled (SVSHE = 0).

$f_{SCAN} = 8$ Hz, $f_{CONVER} = 2$ MHz, COUNTS = 250

(9) CapTlvate technology works in LPM3 with four self-capacitance buttons, wake on touch. CapTlvate BSWP demo panel with 1.5-mm overlay. Current for brownout included. SVS disabled (SVSHE = 0).

$f_{SCAN} = 8$ Hz, $f_{CONVER} = 2$ MHz, COUNTS = 250

(10) CapTlvate technology works in LPM3 with 16 self-capacitance buttons, process only, CapTlvate BSWP demo panel with 1.5-mm overlay. Current for brownout included. SVS disabled (SVSHE = 0).

$f_{SCAN} = 8$ Hz, $f_{CONVER} = 2$ MHz, COUNTS = 250.

(11) CapTlvate technology works in LPM3 with 64 mutual-capacitance buttons, process only. CapTlvate BSWP demo panel with 1.5-mm overlay. Current for brownout included. SVS disabled (SVSHE = 0).

$f_{SCAN} = 8$ Hz, $f_{CONVER} = 2$ MHz, COUNTS = 250.

$f_{SCAN} = 8$ Hz, $f_{CONVER} = 2$ MHz, COUNTS = 250.

$f_{SCAN} = 8$ Hz, $f_{CONVER} = 2$ MHz, COUNTS = 250.

$f_{SCAN} = 8$ Hz, $f_{CONVER} = 2$ MHz, COUNTS = 250.

5.8 Low-Power Mode LPMx.5 Supply Currents (Into V_{CC}) Excluding External Current

over recommended ranges of supply voltage and operating free-air temperature (unless otherwise noted)

PARAMETER		V_{CC}	-40°C		25°C		85°C		UNIT
			TYP	MAX	TYP	MAX	TYP	MAX	
$I_{LPM3.5, XT1}$	Low-power mode 3.5, 12.5-pF crystal, includes SVS ⁽¹⁾⁽²⁾⁽³⁾ (also see Figure 5-2)	3 V	0.65		0.73	0.95	0.99	1.42	μA
		2 V	0.63		0.71		0.87		
$I_{LPM4.5, SVS}$	Low-power mode 4.5, includes SVS ⁽⁴⁾	3 V	0.22		0.24	0.31	0.30	0.38	μA
		2 V	0.21		0.23		0.28		
$I_{LPM4.5}$	Low-power mode 4.5, excludes SVS ⁽⁵⁾	3 V	0.012		0.016	0.055	0.061	0.120	μA
		2 V	0.002		0.007		0.044		

- (1) Not applicable for MCUs with HF crystal oscillator only.
- (2) Characterized with a Micro Crystal MS1V-T1K crystal with a load capacitance of 12.5 pF. The internal and external load capacitance are chosen to closely match the required 12.5-pF load.
- (3) Low-power mode 3.5, 12.5-pF crystal, includes SVS test conditions:
Current for RTC clocked by XT1 included. Current for brownout and SVS included (SVSHE = 1). Core regulator disabled.
PMMREGOFF = 1, CPUOFF = 1, SCG0 = 1 SCG1 = 1, OSCOFF = 1 (LPMx.5),
 $f_{XT1} = 32768 \text{ Hz}$, $f_{ACLK} = 0$, $f_{MCLK} = f_{SMCLK} = 0 \text{ MHz}$
- (4) Low-power mode 4.5, includes SVS test conditions:
Current for brownout and SVS included (SVSHE = 1). Core regulator disabled.
PMMREGOFF = 1, CPUOFF = 1, SCG0 = 1 SCG1 = 1, OSCOFF = 1 (LPMx.5)
 $f_{XT1} = 0 \text{ Hz}$, $f_{ACLK} = f_{MCLK} = f_{SMCLK} = 0 \text{ MHz}$
- (5) Low-power mode 4.5, excludes SVS test conditions:
Current for brownout included. SVS disabled (SVSHE = 0). Core regulator disabled.
PMMREGOFF = 1, CPUOFF = 1, SCG0 = 1 SCG1 = 1, OSCOFF = 1 (LPMx.5)
 $f_{XT1} = 0 \text{ Hz}$, $f_{ACLK} = f_{MCLK} = f_{SMCLK} = 0 \text{ MHz}$

5.9 Typical Characteristics - Low-Power Mode Supply Currents

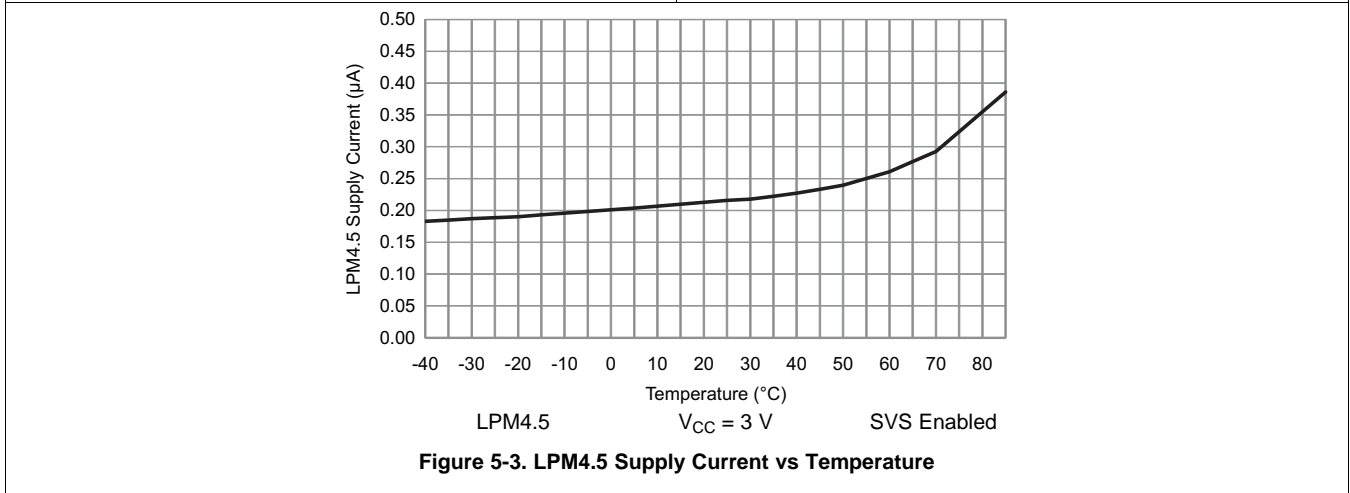
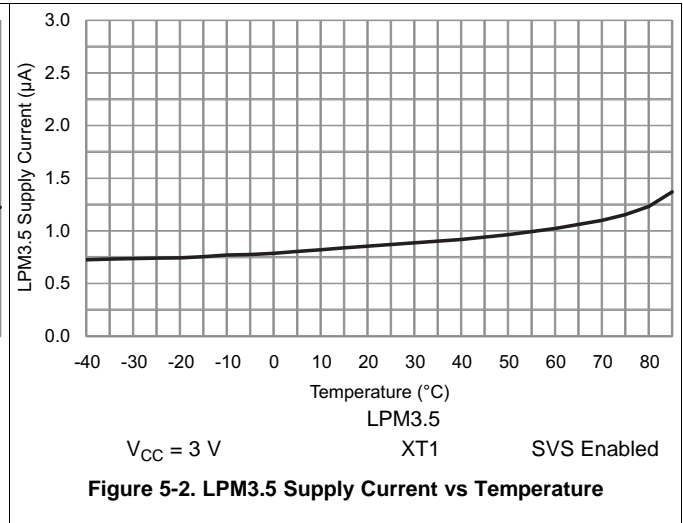
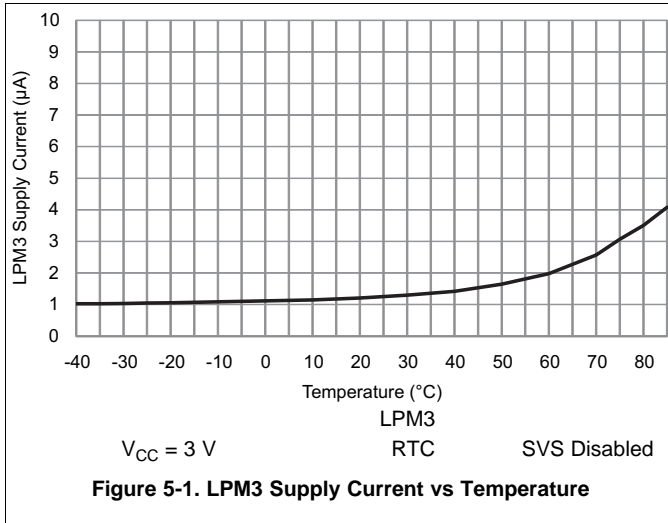

Table 5-1. Typical Characteristics – Current Consumption Per Module

MODULE	TEST CONDITIONS	REFERENCE CLOCK	MIN	TYP	MAX	UNIT
Timer_A		Module input clock		5		μA/MHz
eUSCI_A	UART mode	Module input clock		7		μA/MHz
eUSCI_A	SPI mode	Module input clock		5		μA/MHz
eUSCI_B	SPI mode	Module input clock		5		μA/MHz
eUSCI_B	I ² C mode, 100 kbaud	Module input clock		5		μA/MHz
RTC		32 kHz		85		nA
CRC	From start to end of operation	MCLK		8.5		μA/MHz

5.10 Thermal Resistance Characteristics

		VALUE	UNIT
R θ_{JA}	Junction-to-ambient thermal resistance, still air ⁽¹⁾	VQFN 32 pin (RHB)	33.5
		TSSOP 32 pin (DA)	69.4
		VQFN 24 pin (RGE)	32.6
R θ_{JC}	Junction-to-case (top) thermal resistance ⁽²⁾	VQFN 32 pin (RHB)	25.7
		TSSOP 32 pin (DA)	18.1
		VQFN 24 pin (RGE)	32.4
R θ_{JB}	Junction-to-board thermal resistance	VQFN 32 pin (RHB)	7.6
		TSSOP 32 pin (DA)	33.1
		VQFN 24 pin (RGE)	10.1

- (1) The junction-to-ambient thermal resistance under natural convection is obtained in a simulation on a JEDEC-standard, High-K board, as specified in JESD51-7, in an environment described in JESD51-2a.
- (2) The junction-to-case (top) thermal resistance is obtained by simulating a cold place test on the package top. No specific JEDEC-standard test exists, but a close description can be found in the ANSI SEMI standard G30-88.

5.11 Timing and Switching Characteristics

5.11.1 Power Supply Sequencing

Table 5-2. PMM, SVS and BOR

over recommended ranges of supply voltage and operating free-air temperature (unless otherwise noted)

PARAMETER		TEST CONDITIONS	MIN	TYP	MAX	UNIT
$V_{BOR, safe}$	Safe BOR power-down level ⁽¹⁾		0.1			V
$t_{BOR, safe}$	Safe BOR reset delay ⁽²⁾		10			ms
$I_{SVSH, AM}$	SVS _H current consumption, active mode	$V_{CC} = 3.6\text{ V}$			1.5	μA
$I_{SVSH, LPM}$	SVS _H current consumption, low-power modes	$V_{CC} = 3.6\text{ V}$		240		nA
V_{SVSH-}	SVS _H power-down level		1.71	1.80	1.86	V
V_{SVSH+}	SVS _H power-up level		1.74	1.89	1.99	V
$V_{SVSH, hys}$	SVS _H hysteresis			80		mV
$t_{PD, SVSH, AM}$	SVS _H propagation delay, active mode				10	μs
$t_{PD, SVSH, LPM}$	SVS _H propagation delay, low-power modes				100	μs
$V_{REF, 1.2V}$	1.2-V REF voltage ⁽³⁾		1.158	1.20	1.242	V

(1) A safe BOR can be correctly generated only if DVCC drops below this voltage before it rises.

(2) When an BOR occurs, a safe BOR can be correctly generated only if DVCC is kept low longer than this period before it reaches V_{SVSH+} .

(3) This is a characterized result with external 1-mA load to ground from -40°C to 85°C .

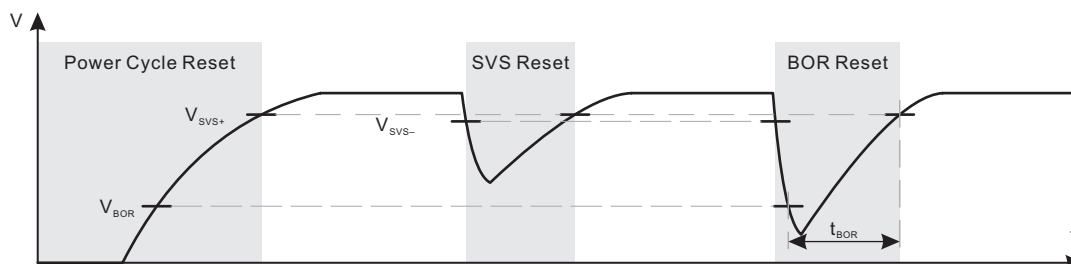

Figure 5-4. Power Cycle, SVS, and BOR Reset Conditions

5.11.2 Reset Timing

Table 5-3. Wake-Up Times From Low-Power Modes and Reset

over recommended ranges of supply voltage and operating free-air temperature (unless otherwise noted)

PARAMETER		TEST CONDITIONS	V _{CC}	MIN	TYP	MAX	UNIT
t _{WAKE-UP FRAM}	Additional wake-up time to activate the FRAM in AM if previously disabled by the FRAM controller or from a LPM if immediate activation is selected for wakeup ⁽¹⁾		3 V		10		μs
t _{WAKE-UP LPM0}	Wake-up time from LPM0 to active mode ⁽¹⁾		3 V			200 + 2.5 / f _{DCO}	ns
t _{WAKE-UP LPM3}	Wake-up time from LPM3 to active mode ⁽²⁾		3 V		10		μs
t _{WAKE-UP LPM4}	Wake-up time from LPM4 to active mode		3 V		10		μs
t _{WAKE-UP LPM3.5}	Wake-up time from LPM3.5 to active mode ⁽²⁾		3 V		350		μs
t _{WAKE-UP LPM4.5}	Wake-up time from LPM4.5 to active mode ⁽²⁾	SVSHE = 1	3 V		350		μs
		SVSHE = 0			1		ms
t _{WAKE-UP-RESET}	Wake-up time from $\overline{\text{RST}}$ or BOR event to active mode ⁽²⁾		3 V		1		ms
t _{RESET}	Pulse duration required at $\overline{\text{RST}}$ /NMI pin to accept a reset		3 V		2		μs

- (1) The wake-up time is measured from the edge of an external wake-up signal (for example, port interrupt or wake-up event) to the first externally observable MCLK clock edge.
- (2) The wake-up time is measured from the edge of an external wake-up signal (for example, port interrupt or wake-up event) until the first instruction of the user program is executed.

5.11.3 Clock Specifications

Table 5-4. XT1 Crystal Oscillator (Low Frequency)

 over recommended ranges of supply voltage and operating free-air temperature (unless otherwise noted)⁽¹⁾

PARAMETER		TEST CONDITIONS	V _{CC}	MIN	TYP	MAX	UNIT
f _{XT1, LF}	XT1 oscillator crystal, low frequency	LFXTBYPASS = 0			32768		Hz
DC _{XT1, LF}	XT1 oscillator LF duty cycle	Measured at MCLK, f _{LFXT} = 32768 Hz		30%		70%	
f _{XT1, SW}	XT1 oscillator logic-level square-wave input frequency	LFXTBYPASS = 1 ⁽²⁾⁽³⁾			32.768		kHz
DC _{XT1, SW}	LFXT oscillator logic-level square-wave input duty cycle	LFXTBYPASS = 1		40%		60%	
OA _{LFXT}	Oscillation allowance for LF crystals ⁽⁴⁾	LFXTBYPASS = 0, LFXTDRIVE = {3}, f _{LFXT} = 32768 Hz, C _{L,eff} = 12.5 pF			200		kΩ
C _{L,eff}	Integrated effective load capacitance ⁽⁵⁾	See ⁽⁶⁾			1		pF
t _{START, LFXT}	Start-up time ⁽⁷⁾	f _{OSC} = 32768 Hz, LFXTBYPASS = 0, LFXTDRIVE = {3}, T _A = 25°C, C _{L,eff} = 12.5 pF			1000		ms
f _{FAULT, LFXT}	Oscillator fault frequency ⁽⁸⁾	XTS = 0 ⁽⁹⁾		0		3500	Hz

- (1) To improve EMI on the LFXT oscillator, observe the following guidelines:
- Keep the trace between the device and the crystal as short as possible.
 - Design a good ground plane around the oscillator pins.
 - Prevent crosstalk from other clock or data lines into oscillator pins XIN and XOUT.
 - Avoid running PCB traces underneath or adjacent to the XIN and XOUT pins.
 - Use assembly materials and processes that avoid any parasitic load on the oscillator XIN and XOUT pins.
 - If conformal coating is used, make sure that it does not induce capacitive or resistive leakage between the oscillator pins.
- (2) When LFXTBYPASS is set, LFXT circuits are automatically powered down. Input signal is a digital square wave with parametrics defined in the Schmitt-trigger inputs section of this data sheet. Duty cycle requirements are defined by DC_{LFXT, SW}.
- (3) Maximum frequency of operation of the entire device cannot be exceeded.
- (4) Oscillation allowance is based on a safety factor of 5 for recommended crystals. The oscillation allowance is a function of the LFXTDRIVE settings and the effective load. In general, comparable oscillator allowance can be achieved based on the following guidelines, but should be evaluated based on the actual crystal selected for the application:
- For LFXTDRIVE = {0}, C_{L,eff} = 3.7 pF
 - For LFXTDRIVE = {1}, 6 pF ≤ C_{L,eff} ≤ 9 pF
 - For LFXTDRIVE = {2}, 6 pF ≤ C_{L,eff} ≤ 10 pF
 - For LFXTDRIVE = {3}, 6 pF ≤ C_{L,eff} ≤ 12 pF
- (5) Includes parasitic bond and package capacitance (approximately 2 pF per pin).
- (6) Requires external capacitors at both terminals. Values are specified by crystal manufacturers.
- (7) Includes start-up counter of 1024 clock cycles.
- (8) Frequencies above the MAX specification do not set the fault flag. Frequencies between the MIN and MAX specifications might set the flag. A static condition or stuck at fault condition sets the flag.
- (9) Measured with logic-level input frequency but also applies to operation with crystals.

Table 5-5. DCO FLL, Frequency

over recommended operating free-air temperature (unless otherwise noted)

PARAMETER		TEST CONDITIONS	V _{CC}	MIN	TYP	MAX	UNIT
f _{DCO, FLL}	FLL lock frequency, 16 MHz, 25°C	Measured at MCLK, Internal trimmed REFO as reference	3 V	-1.0%		1.0%	
	FLL lock frequency, 16 MHz, -40°C to 85°C	Measured at MCLK, Internal trimmed REFO as reference	3 V	-2.0%		2.0%	
	FLL lock frequency, 16 MHz, -40°C to 85°C	Measured at MCLK, XT1 crystal as reference	3 V	-0.5%		0.5%	
f _{DUTY}	Duty cycle		3 V	40%	50%	60%	
Jitter _{CC}	Cycle-to-cycle jitter, 16 MHz	Measured at MCLK, XT1 crystal as reference	3 V		0.25%		
Jitter _{LONG}	Long term jitter, 16 MHz		3 V		0.022%		
t _{FLL, lock}	FLL lock time		3 V		280		ms
t _{start-up}	DCO start-up time, 2 MHz	Measured at MCLK	3 V		16		μs

Table 5-6. DCO Frequency

 over recommended operating free-air temperature (unless otherwise noted) (see [Figure 5-5](#))

PARAMETER	TEST CONDITIONS	V _{CC}	TYP	UNIT
f _{DCO, 16MHz} DCO frequency, 16 MHz	DCORSEL = 101b, DISMOD = 1b, DCOFRIMEN = 1b, DCOFTRIM = 000b, DCO = 0	3 V	7.46	MHz
	DCORSEL = 101b, DISMOD = 1b, DCOFRIMEN = 1b, DCOFTRIM = 000b, DCO = 511		12.26	
	DCORSEL = 101b, DISMOD = 1b, DCOFRIMEN = 1b, DCOFTRIM = 111b, DCO = 0		17.93	
	DCORSEL = 101b, DISMOD = 1b, DCOFRIMEN = 1b, DCOFTRIM = 111b, DCO = 511		29.1	
f _{DCO, 12MHz} DCO frequency, 12 MHz	DCORSEL = 100b, DISMOD = 1b, DCOFRIMEN = 1b, DCOFTRIM = 000b, DCO = 0	3 V	5.75	MHz
	DCORSEL = 100b, DISMOD = 1b, DCOFRIMEN = 1b, DCOFTRIM = 000b, DCO = 511		9.5	
	DCORSEL = 100b, DISMOD = 1b, DCOFRIMEN = 1b, DCOFTRIM = 111b, DCO = 0		13.85	
	DCORSEL = 100b, DISMOD = 1b, DCOFRIMEN = 1b, DCOFTRIM = 111b, DCO = 511		22.5	
f _{DCO, 8MHz} DCO frequency, 8 MHz	DCORSEL = 011b, DISMOD = 1b, DCOFRIMEN = 1b, DCOFTRIM = 000b, DCO = 0	3 V	3.91	MHz
	DCORSEL = 011b, DISMOD = 1b, DCOFRIMEN = 1b, DCOFTRIM = 000b, DCO = 511		6.49	
	DCORSEL = 011b, DISMOD = 1b, DCOFRIMEN = 1b, DCOFTRIM = 111b, DCO = 0		9.5	
	DCORSEL = 011b, DISMOD = 1b, DCOFRIMEN = 1b, DCOFTRIM = 111b, DCO = 511		15.6	
f _{DCO, 4MHz} DCO frequency, 4 MHz	DCORSEL = 010b, DISMOD = 1b, DCOFRIMEN = 1b, DCOFTRIM = 000b, DCO = 0	3 V	2.026	MHz
	DCORSEL = 010b, DISMOD = 1b, DCOFRIMEN = 1b, DCOFTRIM = 000b, DCO = 511		3.407	
	DCORSEL = 010b, DISMOD = 1b, DCOFRIMEN = 1b, DCOFTRIM = 111b, DCO = 0		4.95	
	DCORSEL = 010b, DISMOD = 1b, DCOFRIMEN = 1b, DCOFTRIM = 111b, DCO = 511		8.26	
f _{DCO, 2MHz} DCO frequency, 2 MHz	DCORSEL = 001b, DISMOD = 1b, DCOFRIMEN = 1b, DCOFTRIM = 000b, DCO = 0	3 V	1.0225	MHz
	DCORSEL = 001b, DISMOD = 1b, DCOFRIMEN = 1b, DCOFTRIM = 000b, DCO = 511		1.729	
	DCORSEL = 001b, DISMOD = 1b, DCOFRIMEN = 1b, DCOFTRIM = 111b, DCO = 0		2.525	
	DCORSEL = 001b, DISMOD = 1b, DCOFRIMEN = 1b, DCOFTRIM = 111b, DCO = 511		4.25	
f _{DCO, 1MHz} DCO frequency, 1 MHz	DCORSEL = 000b, DISMOD = 1b, DCOFRIMEN = 1b, DCOFTRIM = 000b, DCO = 0	3 V	0.5319	MHz
	DCORSEL = 000b, DISMOD = 1b, DCOFRIMEN = 1b, DCOFTRIM = 000b, DCO = 511		0.9029	
	DCORSEL = 000b, DISMOD = 1b, DCOFRIMEN = 1b, DCOFTRIM = 111b, DCO = 0		1.307	
	DCORSEL = 000b, DISMOD = 1b, DCOFRIMEN = 1b, DCOFTRIM = 111b, DCO = 511		2.21	

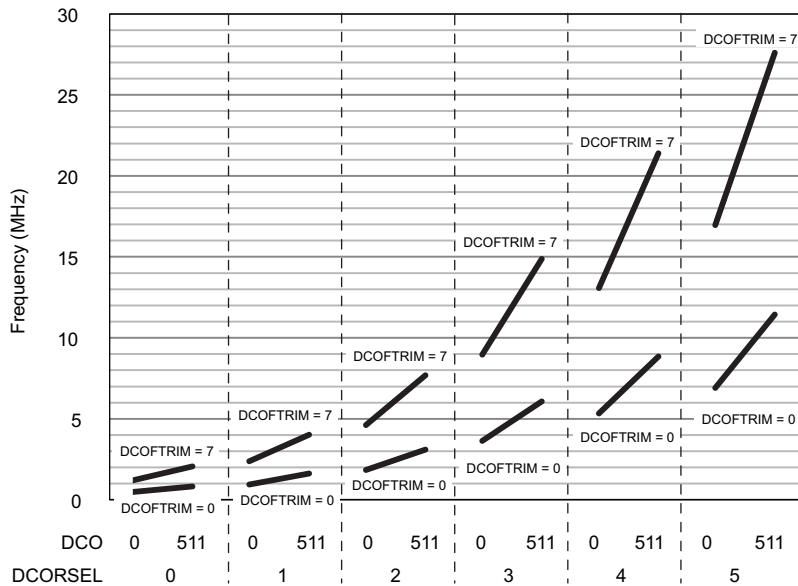

V_{CC} = 3 V T_A = -40°C to 85°C

Figure 5-5. Typical DCO Frequency

Table 5-7. REFO

over recommended operating free-air temperature (unless otherwise noted)

PARAMETER		TEST CONDITIONS	V _{CC}	MIN	TYP	MAX	UNIT
I _{REFO}	REFO oscillator current consumption	T _A = 25°C	3 V		15		μA
f _{REFO}	REFO calibrated frequency	Measured at MCLK	3 V		32768		Hz
	REFO absolute calibrated tolerance	-40°C to 85°C	1.8 V to 3.6 V	-3.5%		+3.5%	
df _{REFO} /dT	REFO frequency temperature drift	Measured at MCLK ⁽¹⁾	3 V		0.01		%/°C
df _{REFO} /dV _{CC}	REFO frequency supply voltage drift	Measured at MCLK at 25°C ⁽²⁾	1.8 V to 3.6 V		1		%/V
f _{DC}	REFO duty cycle	Measured at MCLK	1.8 V to 3.6 V	40%	50%	60%	
t _{START}	REFO start-up time	40% to 60% duty cycle			50		μs

(1) Calculated using the box method: (MAX(-40°C to 85°C) – MIN(-40°C to 85°C)) / MIN(-40°C to 85°C) / (85°C – (-40°C))

(2) Calculated using the box method: (MAX(1.8 V to 3.6 V) – MIN(1.8 V to 3.6 V)) / MIN(1.8 V to 3.6 V) / (3.6 V – 1.8 V)

Table 5-8. Internal Very-Low-Power Low-Frequency Oscillator (VLO)

over recommended ranges of supply voltage and operating free-air temperature (unless otherwise noted)

PARAMETER		TEST CONDITIONS	V _{CC}	TYP	UNIT
f _{VLO}	VLO frequency	Measured at MCLK	3 V	10	kHz
df _{VLO} /dT	VLO frequency temperature drift	Measured at MCLK ⁽¹⁾	3 V	0.5	%/°C
df _{VLO} /dV _{CC}	VLO frequency supply voltage drift	Measured at MCLK ⁽²⁾	1.8 V to 3.6 V	4	%/V
f _{VLO,DC}	Duty cycle	Measured at MCLK	3 V	50%	

(1) Calculated using the box method: (MAX(-40°C to 85°C) – MIN(-40°C to 85°C)) / MIN(-40°C to 85°C) / (85°C – (-40°C))

(2) Calculated using the box method: (MAX(1.8 V to 3.6 V) – MIN(1.8 V to 3.6 V)) / MIN(1.8 V to 3.6 V) / (3.6 V – 1.8 V)

NOTE

The VLO clock frequency is reduced by 15% (typical) when the device switches from active mode to LPM3 or LPM4, because the reference changes. This lower frequency is not a violation of the VLO specifications (see Table 5-8).

Table 5-9. Module Oscillator (MODOSC)

over recommended ranges of supply voltage and operating free-air temperature (unless otherwise noted)

PARAMETER		TEST CONDITIONS	V _{CC}	MIN	TYP	MAX	UNIT
f _{MODOSC}	MODOSC frequency		3 V	3.8	4.8	5.8	MHz
f _{MODOSC} /dT	MODOSC frequency temperature drift		3 V	0.102			%/°C
f _{MODOSC} /dV _{CC}	MODOSC frequency supply voltage drift		1.8 V to 3.6 V	1.02			%/V
f _{MODOSC,DC}	Duty cycle		3 V	40%	50%	60%	

5.11.4 Digital I/Os

Table 5-10. Digital Inputs

over recommended ranges of supply voltage and operating free-air temperature (unless otherwise noted)

PARAMETER		TEST CONDITIONS	V _{CC}	MIN	TYP	MAX	UNIT
V _{IT+}	Positive-going input threshold voltage		2 V	0.90		1.50	V
			3 V	1.35		2.25	
V _{IT-}	Negative-going input threshold voltage		2 V	0.50		1.10	V
			3 V	0.75		1.65	
V _{hys}	Input voltage hysteresis (V _{IT+} – V _{IT-})		2 V	0.3		0.8	V
			3 V	0.4		1.2	
R _{Pull}	Pullup or pulldown resistor	For pullup: V _{IN} = V _{SS} For pulldown: V _{IN} = V _{CC}		20	35	50	kΩ
C _{I,dig}	Input capacitance, digital only port pins	V _{IN} = V _{SS} or V _{CC}			3		pF
C _{I,ana}	Input capacitance, port pins with shared analog functions	V _{IN} = V _{SS} or V _{CC}			5		pF
I _{lkg(Px.y)}	High-impedance leakage current	See ⁽¹⁾ ⁽²⁾	2 V, 3 V	-20		20	nA

(1) The leakage current is measured with V_{SS} or V_{CC} applied to the corresponding pins, unless otherwise noted.

(2) The leakage of the digital port pins is measured individually. The port pin is selected for input and the pullup or pulldown resistor is disabled.

Table 5-11. Digital Outputs

over recommended ranges of supply voltage and operating free-air temperature (unless otherwise noted)

PARAMETER		TEST CONDITIONS	V _{CC}	MIN	TYP	MAX	UNIT
V _{OH}	High-level output voltage	I _(OHmax) = -3 mA ⁽¹⁾	2 V	1.4		2.0	V
		I _(OHmax) = -5 mA ⁽¹⁾	3 V	2.4		3.0	
V _{OL}	Low-level output voltage	I _(OLmax) = 3 mA ⁽¹⁾	2 V	0.0		0.60	V
		I _(OHmax) = 5 mA ⁽¹⁾	3 V	0.0		0.60	
f _{Port_CLK}	Clock output frequency	C _L = 20 pF ⁽²⁾	2 V	16			MHz
			3 V	16			
t _{rise,dig}	Port output rise time, digital only port pins	C _L = 20 pF	2 V	10			ns
			3 V	7			
t _{fall,dig}	Port output fall time, digital only port pins	C _L = 20 pF	2 V	10			ns
			3 V	5			

(1) The maximum total current, I_(OHmax) and I_(OLmax), for all outputs combined should not exceed ±48 mA to hold the maximum voltage drop specified.

(2) The port can output frequencies at least up to the specified limit and might support higher frequencies.

5.11.4.1 Typical Characteristics – Outputs at 3 V and 2 V

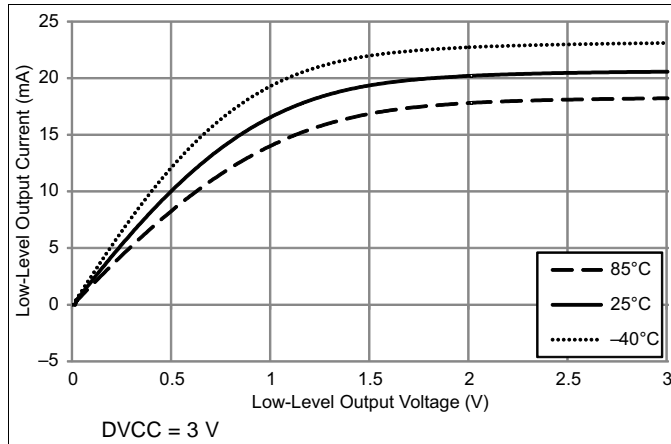

Figure 5-6. Typical Low-Level Output Current vs Low-Level Output Voltage

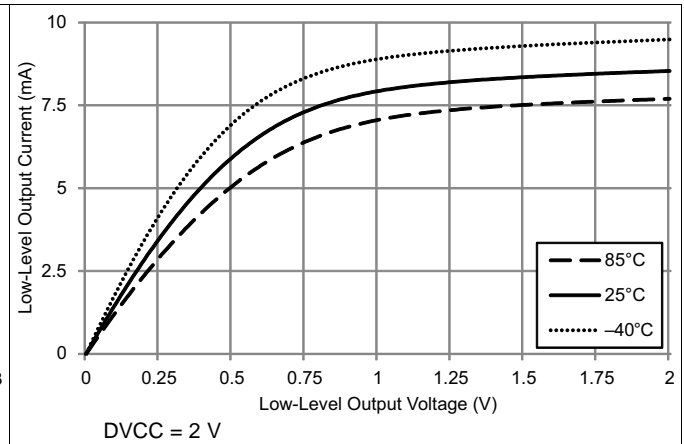

Figure 5-7. Typical Low-Level Output Current vs Low-Level Output Voltage

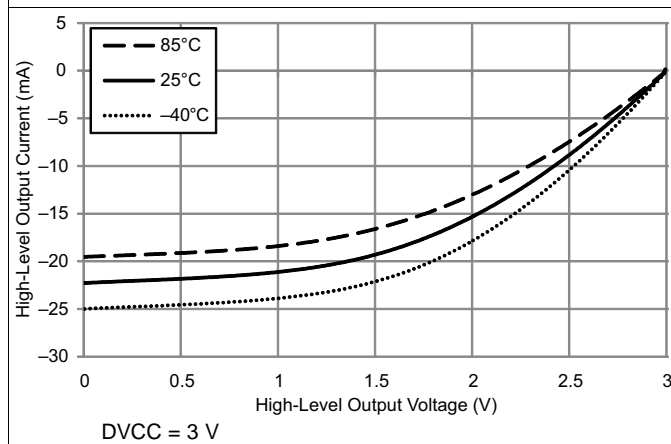

Figure 5-8. Typical High-Level Output Current vs High-Level Output Voltage

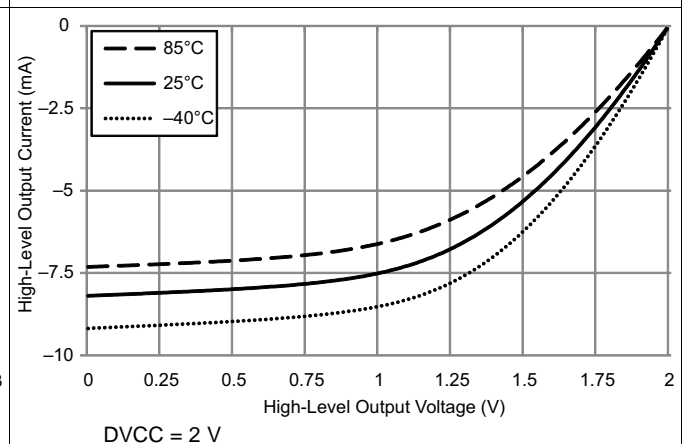

Figure 5-9. Typical High-Level Output Current vs High-Level Output Voltage

5.11.5 VREF+ Built-in Reference

Table 5-12. VREF+

over recommended ranges of supply voltage and operating free-air temperature (unless otherwise noted)

PARAMETER	TEST CONDITIONS	V _{CC}	MIN	TYP	MAX	UNIT
V _{REF+}	Positive built-in reference voltage EXTREFEN = 1 with 1-mA load current	2 V, 3 V	1.15	1.19	1.23	V
TC _{REF+}	Temperature coefficient of built-in reference voltage			30		μV/°C

5.11.6 Timer_A

Table 5-13. Timer_A

over recommended ranges of supply voltage and operating free-air temperature (unless otherwise noted)

PARAMETER	TEST CONDITIONS	V _{CC}	MIN	TYP	MAX	UNIT
f _{TA}	Timer_A input clock frequency Internal: SMCLK, ACLK External: TACLK Duty cycle = 50% ±10%	2 V, 3 V			16	MHz

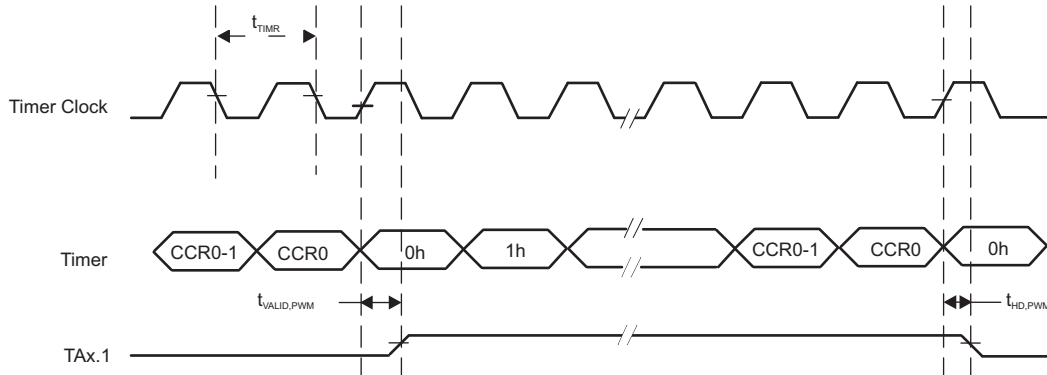

Figure 5-10. Timer PWM Mode

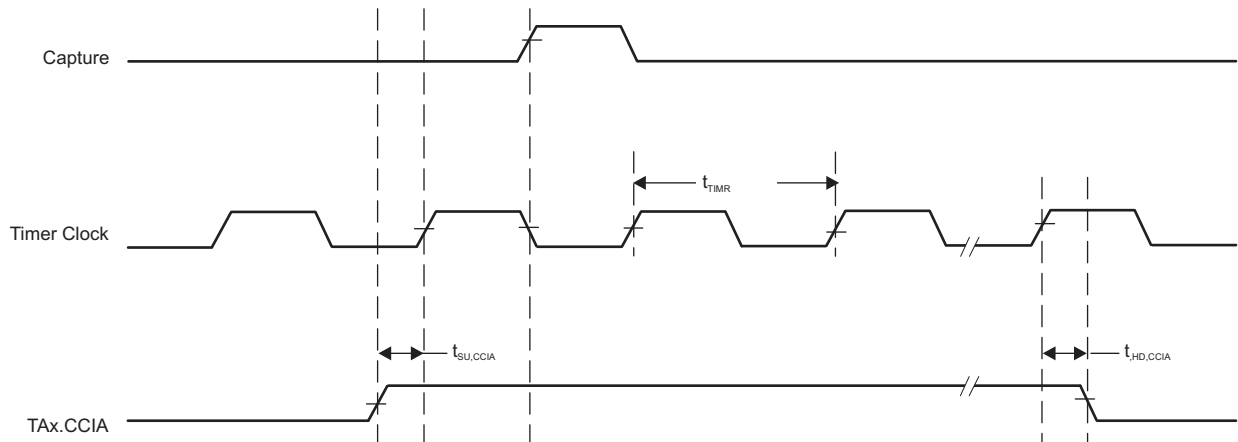

Figure 5-11. Timer Capture Mode

5.11.7 eUSCI

Table 5-14. eUSCI (UART Mode) Clock Frequency

over recommended ranges of supply voltage and operating free-air temperature (unless otherwise noted)

PARAMETER		TEST CONDITIONS	V _{CC}	MIN	MAX	UNIT
f _{eUSCI}	eUSCI input clock frequency	Internal: SMCLK, MODCLK External: UCLK Duty cycle = 50% ±10%	2 V, 3 V		16	MHz
f _{BITCLK}	BITCLK clock frequency (equals baud rate in Mbaud)		2 V, 3 V		5	MHz

Table 5-15. eUSCI (UART Mode)

over recommended ranges of supply voltage and operating free-air temperature (unless otherwise noted)

PARAMETER		TEST CONDITIONS	V _{CC}	TYP	UNIT
t _t	UART receive deglitch time ⁽¹⁾	UCGLITx = 0	2 V, 3 V	12	ns
		UCGLITx = 1		40	
		UCGLITx = 2		68	
		UCGLITx = 3		110	

- (1) Pulses on the UART receive input (UCxRX) shorter than the UART receive deglitch time are suppressed. To ensure that pulses are correctly recognized, their duration should exceed the maximum specification of the deglitch time.

Table 5-16. eUSCI (SPI Master Mode) Clock Frequency

over recommended ranges of supply voltage and operating free-air temperature (unless otherwise noted)

PARAMETER		TEST CONDITIONS	MIN	MAX	UNIT
f _{eUSCI}	eUSCI input clock frequency	Internal: SMCLK, MODCLK Duty cycle = 50% ±10%		8	MHz

Table 5-17. eUSCI (SPI Master Mode)

over recommended ranges of supply voltage and operating free-air temperature (unless otherwise noted) ⁽¹⁾

PARAMETER		TEST CONDITIONS	V _{CC}	MIN	MAX	UNIT
t _{STE,LEAD}	STE lead time, STE active to clock	UCSTEM = 0, UCMODEx = 01 or 10		1		UCxCLK cycles
		UCSTEM = 1, UCMODEx = 01 or 10				
t _{STE,LAG}	STE lag time, last clock to STE inactive	UCSTEM = 0, UCMODEx = 01 or 10		1		UCxCLK cycles
		UCSTEM = 1, UCMODEx = 01 or 10				
t _{SU,MI}	SOMI input data setup time		2 V	45		ns
			3 V	35		
t _{HD,MI}	SOMI input data hold time		2 V	0		ns
			3 V	0		
t _{VALID,MO}	SIMO output data valid time ⁽²⁾	UCLK edge to SIMO valid, C _L = 20 pF	2 V		20	ns
			3 V		20	
t _{HD,MO}	SIMO output data hold time ⁽³⁾	C _L = 20 pF	2 V	0		ns
			3 V	0		

- (1) $f_{UCxCLK} = 1/2t_{LO/HI}$ with $t_{LO/HI} = \max(t_{VALID,MO}(eUSCI) + t_{SU,SI}(Slave), t_{SU,MI}(eUSCI) + t_{VALID,SO}(Slave))$. For the slave parameters $t_{SU,SI}(Slave)$ and $t_{VALID,SO}(Slave)$, see the SPI parameters of the attached slave.
- (2) Specifies the time to drive the next valid data to the SIMO output after the output changing UCLK clock edge. Refer to the timing diagrams in [Figure 5-12](#) and [Figure 5-13](#).
- (3) Specifies how long data on the SIMO output is valid after the output changing UCLK clock edge. Negative values indicate that the data on the SIMO output can become invalid before the output changing clock edge observed on UCLK. Refer to the timing diagrams in [Figure 5-12](#) and [Figure 5-13](#).

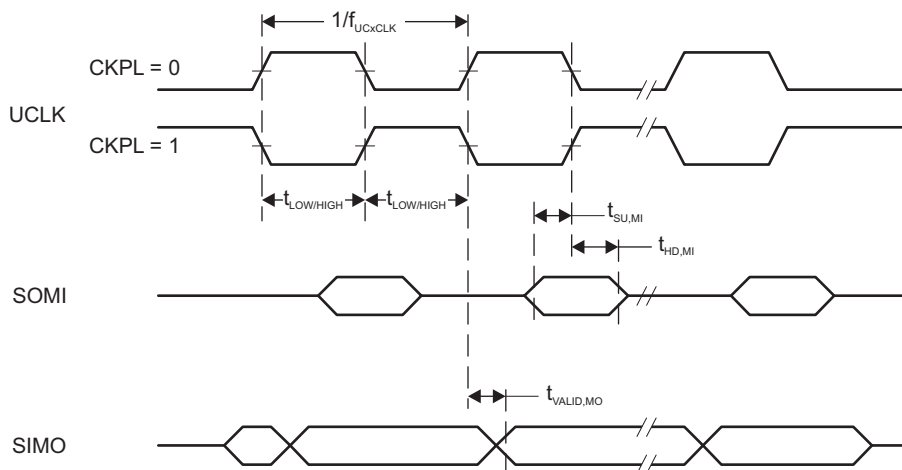

Figure 5-12. SPI Master Mode, CKPH = 0

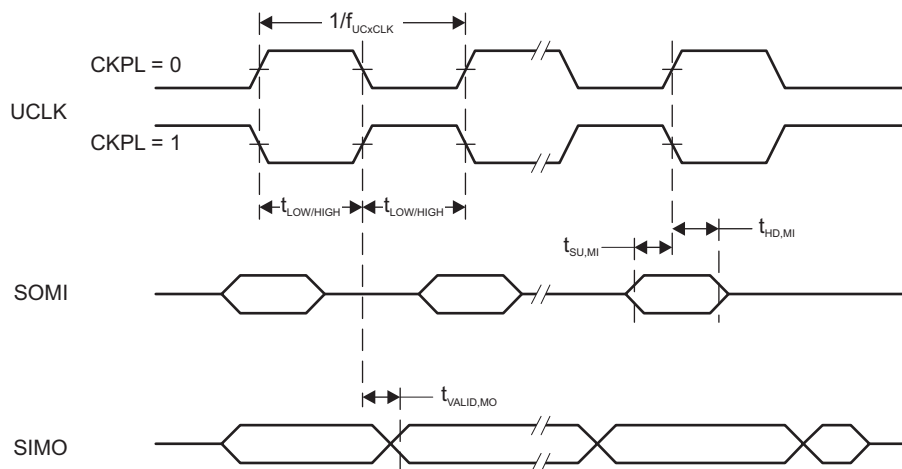

Figure 5-13. SPI Master Mode, CKPH = 1

Table 5-18. eUSCI (SPI Slave Mode)over recommended ranges of supply voltage and operating free-air temperature (unless otherwise noted)⁽¹⁾

PARAMETER		TEST CONDITIONS	V _{CC}	MIN	MAX	UNIT
t _{STE,LEAD}	STE lead time, STE active to clock		2 V	55		ns
			3 V	45		
t _{STE,LAG}	STE lag time, Last clock to STE inactive		2 V	20		ns
			3 V	20		
t _{STE,ACC}	STE access time, STE active to SOMI data out		2 V		65	ns
			3 V		40	
t _{STE,DIS}	STE disable time, STE inactive to SOMI high impedance		2 V		40	ns
			3 V		35	
t _{SU,SI}	SIMO input data setup time		2 V	6		ns
			3 V	4		
t _{HD,SI}	SIMO input data hold time		2 V	12		ns
			3 V	12		
t _{VALID,SO}	SOMI output data valid time ⁽²⁾	UCLK edge to SOMI valid, C _L = 20 pF	2 V		65	ns
			3 V		40	
t _{HD,SO}	SOMI output data hold time ⁽³⁾	C _L = 20 pF	2 V	5		ns
			3 V	5		

(1) $f_{UCxCLK} = 1/2t_{LO/HI}$ with $t_{LO/HI} \geq \max(t_{VALID,MO(Master)} + t_{SU,SI(eUSCI)}, t_{SU,MI(Master)} + t_{VALID,SO(eUSCI)})$.For the master parameters $t_{SU,MI(Master)}$ and $t_{VALID,MO(Master)}$, see the SPI parameters of the attached master.(2) Specifies the time to drive the next valid data to the SOMI output after the output changing UCLK clock edge. Refer to the timing diagrams in [Figure 5-14](#) and [Figure 5-15](#).(3) Specifies how long data on the SOMI output is valid after the output changing UCLK clock edge. Refer to the timing diagrams in [Figure 5-14](#) and [Figure 5-15](#).

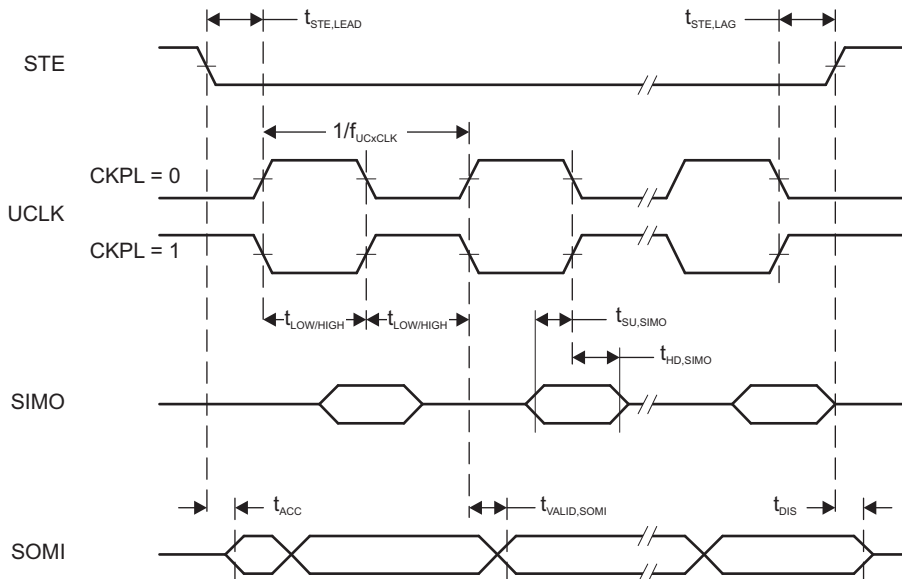

Figure 5-14. SPI Slave Mode, CKPH = 0

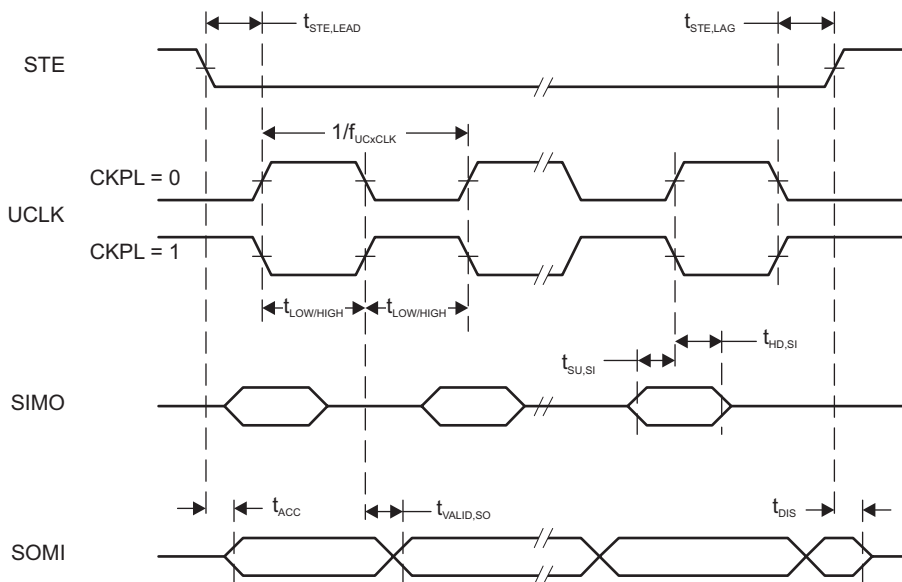

Figure 5-15. SPI Slave Mode, CKPH = 1

Table 5-19. eUSCI (I²C Mode)

over recommended ranges of supply voltage and operating free-air temperature (unless otherwise noted) (see [Figure 5-16](#))

PARAMETER	TEST CONDITIONS	V _{CC}	MIN	TYP	MAX	UNIT
f _{eUSCI} eUSCI input clock frequency	Internal: SMCLK, MODCLK External: UCLK Duty cycle = 50% ±10%				16	MHz
f _{SCL} SCL clock frequency		2 V, 3 V	0		400	kHz
t _{HD,STA} Hold time (repeated) START	f _{SCL} = 100 kHz f _{SCL} > 100 kHz	2 V, 3 V	4.0 0.6			μs
t _{SU,STA} Setup time for a repeated START	f _{SCL} = 100 kHz f _{SCL} > 100 kHz	2 V, 3 V	4.7 0.6			μs
t _{HD,DAT} Data hold time		2 V, 3 V	0			ns
t _{SU,DAT} Data setup time		2 V, 3 V	250			ns
t _{SU,STO} Setup time for STOP	f _{SCL} = 100 kHz f _{SCL} > 100 kHz	2 V, 3 V	4.0 0.6			μs
t _{SP} Pulse duration of spikes suppressed by input filter	UCGLITx = 0	2 V, 3 V	50		600	ns
	UCGLITx = 1		25	300		
	UCGLITx = 2		12.5	150		
	UCGLITx = 3		6.3	75		
t _{TIMEOUT} Clock low time-out	UCCLTOx = 1	2 V, 3 V		27		ms
	UCCLTOx = 2			30		
	UCCLTOx = 3			33		

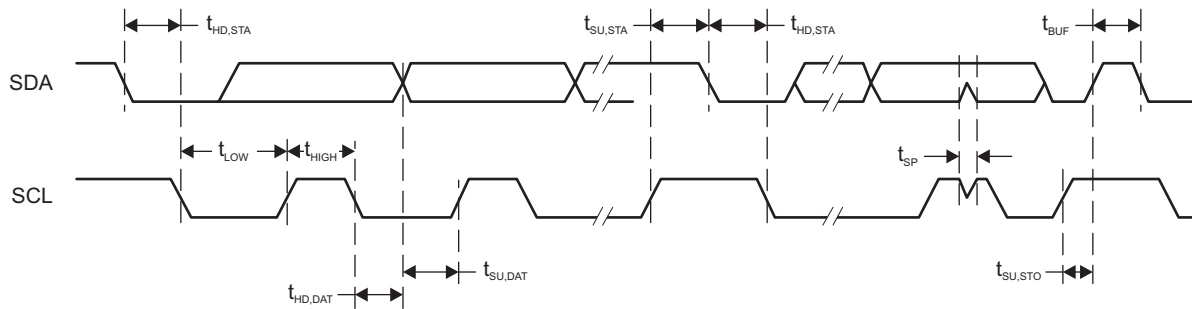

Figure 5-16. I²C Mode Timing

5.11.8 ADC

Table 5-20. ADC, Power Supply and Input Range Conditions

over operating free-air temperature range (unless otherwise noted)

PARAMETER		TEST CONDITIONS	V _{CC}	MIN	TYP	MAX	UNIT
DV _{CC}	ADC supply voltage			2.0		3.6	V
V _(Ax)	Analog input voltage range	All ADC pins		0		DV _{CC}	V
I _{ADC}	Operating supply current into DV _{CC} terminal, reference current not included, repeat-single-channel mode	f _{ADCCLK} = 5 MHz, ADCON = 1, REFON = 0, SHT0 = 0, SHT1 = 0, ADCDIV = 0, ADCCONSEQx = 10b	2 V	185			μA
			3 V	207			
C _I	Input capacitance	Only one terminal Ax can be selected at one time, from the pad to the ADC capacitor array, including wiring and pad	2.2 V		1.6	2.0	pF
R _I	Input MUX ON resistance	DV _{CC} = 2 V, 0 V = V _{Ax} = DV _{CC}				2	kΩ

Table 5-21. ADC, 10-Bit Timing Parameters

over operating free-air temperature range (unless otherwise noted)

PARAMETER		TEST CONDITIONS	V _{CC}	MIN	TYP	MAX	UNIT
f _{ADCCLK}		For specified performance of ADC linearity parameters	2 V to 3.6 V	0.45	5	5.5	MHz
f _{ADCOSC}	Internal ADC oscillator (MODOSC)	ADCDIV = 0, f _{ADCCLK} = f _{ADCOSC}	2 V to 3.6 V	4.5	5.0	5.5	MHz
t _{CONVERT}	Conversion time	REFON = 0, Internal oscillator, 10 ADCCLK cycles, 10-bit mode, f _{ADCOSC} = 4.5 MHz to 5.5 MHz	2 V to 3.6 V	2.18		2.67	μs
		External f _{ADCCLK} from ACLK or SMCLK, ADCSSEL ≠ 0	2 V to 3.6 V	See ⁽¹⁾			
t _{ADCON}	Turnon settling time of the ADC	The error in a conversion started after t _{ADCON} is less than ±0.5 LSB, Reference and input signal already settled				100	ns
t _{Sample}	Sampling time	R _S = 1000 Ω, R _I = 36000 Ω, C _I = 3.5 pF, Approximately 8 Tau (t) are required for an error of less than ±0.5 LSB	2 V	1.5			μs
			3 V	2.0			

(1) $12 \times \text{ADCDIV} \times 1 / f_{\text{ADCCLK}}$

Table 5-22. ADC, 10-Bit Linearity Parameters

over operating free-air temperature range (unless otherwise noted)

PARAMETER		TEST CONDITIONS	V _{CC}	MIN	TYP	MAX	UNIT
E _I	Integral linearity error (10-bit mode)	V _{eref+} as reference	2.4 V to 3.6 V	-2		2	LSB
	Integral linearity error (8-bit mode)		2 V to 3.6 V	-2		2	
E _D	Differential linearity error (10-bit mode)	V _{eref+} as reference	2.4 V to 3.6 V	-1		1	LSB
	Differential linearity error (8-bit mode)		2 V to 3.6 V	-1		1	
E _O	Offset error (10-bit mode)	V _{eref+} as reference	2.4 V to 3.6 V	-6.5		6.5	mV
	Offset error (8-bit mode)		2 V to 3.6 V	-6.5		6.5	
E _G	Gain error (10-bit mode)	V _{eref+} as reference	2.4 V to 3.6 V	-2.0		2.0	LSB
		Internal 1.5-V reference		-3.0%		3.0%	
	Gain error (8-bit mode)	V _{eref+} as reference	2 V to 3.6 V	-2.0		2.0	LSB
		Internal 1.5-V reference		-3.0%		3.0%	
E _T	Total unadjusted error (10-bit mode)	V _{eref+} as reference	2.4 V to 3.6 V	-2.0		2.0	LSB
		Internal 1.5-V reference		-3.0%		3.0%	
	Total unadjusted error (8-bit mode)	V _{eref+} as reference	2 V to 3.6 V	-2.0		2.0	LSB
		Internal 1.5-V reference		-3.0%		3.0%	
V _{SENSOR}	See ⁽¹⁾	ADCON = 1, INCH = 0Ch, T _A = 0°C	3 V		913		mV
TC _{SENSOR}	See ⁽²⁾	ADCON = 1, INCH = 0Ch	3 V		3.35		mV/°C
t _{SENSOR (sample)}	Sample time required if channel 12 is selected ⁽³⁾	ADCON = 1, INCH = 0Ch, Error of conversion result ≤ 1 LSB, AM and all LPMs above LPM3	3 V		30		μs
		ADCON = 1, INCH = 0Ch, Error of conversion result ≤ 1 LSB, LPM3	3 V		100		

- (1) The temperature sensor offset can vary significantly. TI recommends a single-point calibration to minimize the offset error of the built-in temperature sensor.
- (2) The device descriptor structure contains calibration values for 30°C ±3°C and 85°C ±3°C for each of the available reference voltage levels. The sensor voltage can be computed as $V_{SENSE} = TC_{SENSOR} \times (\text{Temperature, } ^\circ\text{C}) + V_{SENSOR}$, where TC_{SENSOR} and V_{SENSOR} can be computed from the calibration values for higher accuracy.
- (3) The typical equivalent impedance of the sensor is 700 kΩ. The sample time required includes the sensor on time, t_{SENSOR(on)}.

5.11.9 CapTivate

Table 5-23. CapTivate Electrical Characteristics

over operating free-air temperature range (unless otherwise noted)

PARAMETER		TEST CONDITIONS	MIN	TYP	MAX	UNIT
V_{REG}	Reference voltage output		1.5	1.55	1.6	V
$t_{WAKEUP,COLD}$	Voltage regulator wake-up time: LDO completely off then turned on				1	ms
$t_{WAKEUP,WARM}$	Voltage regulator wake-up time: LDO in low-power mode then turned on				300	us
f_{CAPCLK}	Captivate oscillator frequency, nominal	$T_A = 25^\circ\text{C}$, CAPCLK0, FREQSHFT = 00b	-3%	16	+3%	MHz
$f_{CAPCLK,DC}$	Duty cycle	Duty cycle (excluding first clock cycle, $DC = t_{high} \times f$)	40%	50%	60%	

5.11.10 FRAM

Table 5-24. FRAM

over recommended ranges of supply voltage and operating free-air temperature (unless otherwise noted)

PARAMETER	TEST CONDITIONS	MIN	TYP	MAX	UNIT
Read and write endurance		10 ¹⁵			cycles
t _{Retention} Data retention duration	T _J = 25°C	100			years
	T _J = 70°C	40			
	T _J = 85°C	10			
I _{WRITE} Current to write into FRAM			I _{READ} ⁽¹⁾		nA
I _{ERASE} Erase current			N/A ⁽²⁾		nA
t _{WRITE} Write time			t _{READ} ⁽³⁾		ns
t _{READ} Read time	NWAITSx = 0		1 / f _{SYSTEM} ⁽⁴⁾		ns
	NWAITSx = 1		2 / f _{SYSTEM} ⁽⁴⁾		

- (1) Writing to FRAM does not require a setup sequence or additional power when compared to reading from FRAM. The FRAM read current I_{READ} is included in the active mode current consumption parameter I_{AM,FRAM}.
- (2) FRAM does not require a special erase sequence.
- (3) Writing into FRAM is as fast as reading.
- (4) The maximum read (and write) speed is specified by f_{SYSTEM} using the appropriate wait state settings (NWAITSx).

5.11.11 Debug and Emulation

Table 5-25. JTAG, Spy-Bi-Wire Interface

over recommended ranges of supply voltage and operating free-air temperature (unless otherwise noted) (see [Figure 5-17](#))

PARAMETER		V _{CC}	MIN	TYP	MAX	UNIT
f _{SBW}	Spy-Bi-Wire input frequency	2 V, 3 V	0		10	MHz
t _{SBW,Low}	Spy-Bi-Wire low clock pulse duration	2 V, 3 V	0.028		15	μs
t _{SU, SBWTDIO}	SBWTDIO setup time (before falling edge of SBWTCK in TMS and TDI slot, Spy-Bi-Wire)	2 V, 3 V	4			ns
t _{HD, SBWTDIO}	SBWTDIO hold time (after rising edge of SBWTCK in TMS and TDI slot, Spy-Bi-Wire)	2 V, 3 V	19			ns
t _{valid, SBWTDIO}	SBWTDIO data valid time (after falling edge of SBWTCK in TDO slot, Spy-Bi-Wire)	2 V, 3 V			31	ns
t _{SBW, En}	Spy-Bi-Wire enable time (TEST high to acceptance of first clock edge) ⁽¹⁾	2 V, 3 V			110	μs
t _{SBW, Ret}	Spy-Bi-Wire return to normal operation time ⁽²⁾	2 V, 3 V	15		100	μs
R _{internal}	Internal pulldown resistance on TEST	2 V, 3 V	20	35	50	kΩ

- (1) Tools that access the Spy-Bi-Wire interface must wait for the t_{SBW,En} time after pulling the TEST/SBWTCK pin high before applying the first SBWTCK clock edge.
- (2) Maximum t_{SBW,Ret} time after pulling or releasing the TEST/SBWTCK pin low until the Spy-Bi-Wire pins revert from their Spy-Bi-Wire function to their application function. This time applies only if the Spy-Bi-Wire mode is selected.

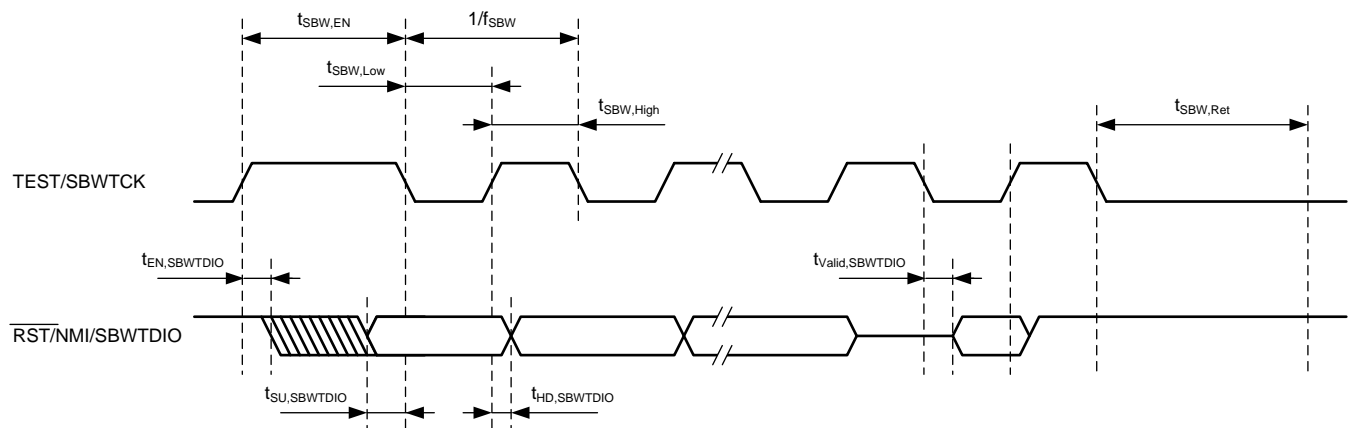

Figure 5-17. JTAG Spy-Bi-Wire Timing

Table 5-26. JTAG, 4-Wire Interface

over recommended ranges of supply voltage and operating free-air temperature (unless otherwise noted) (see [Figure 5-18](#))

PARAMETER		V _{CC}	MIN	TYP	MAX	UNIT
f _{TCK}	TCK input frequency ⁽¹⁾	2 V, 3 V	0		10	MHz
t _{TCK,Low}	TCK low clock pulse duration	2 V, 3 V	15			ns
t _{TCK,High}	TCK high clock pulse duration	2 V, 3 V	15			ns
t _{SU,TMS}	TMS setup time (before rising edge of TCK)	2 V, 3 V	11			ns
t _{HD,TMS}	TMS hold time (after rising edge of TCK)	2 V, 3 V	3			ns
t _{SU,TDI}	TDI setup time (before rising edge of TCK)	2 V, 3 V	13			ns
t _{HD,TDI}	TDI hold time (after rising edge of TCK)	2 V, 3 V	5			ns
t _{Z-Valid,TDO}	TDO high impedance to valid output time (after falling edge of TCK)	2 V, 3 V			26	ns
t _{Valid,TDO}	TDO to new valid output time (after falling edge of TCK)	2 V, 3 V			26	ns
t _{Valid-Z,TDO}	TDO valid to high-impedance output time (after falling edge of TCK)	2 V, 3 V			26	ns
t _{JTAG,Ret}	Spy-Bi-Wire return to normal operation time		15		100	μs
R _{internal}	Internal pulldown resistance on TEST	2 V, 3 V	20	35	50	kΩ

(1) f_{TCK} may be restricted to meet the timing requirements of the module selected.

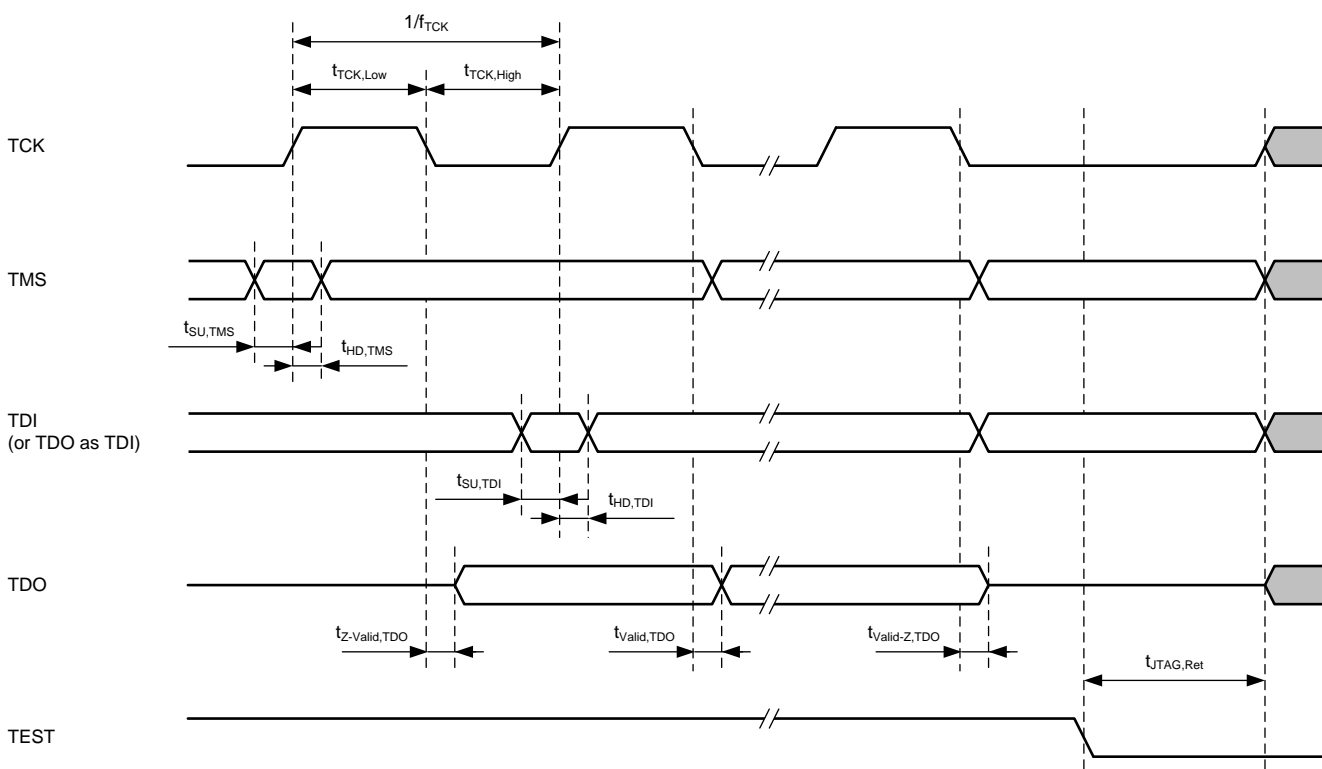

Figure 5-18. JTAG 4-Wire Timing

6 Detailed Description

6.1 Overview

The MSP430FR263x and MSP430FR253x ultra-low-power MCUs are the first FRAM-based MCUs with integrated high-performance charge-transfer CapTIvate technology in ultra-low-power high-reliability high-flexibility MCUs. The MSP430FR263x and MSP430FR253x MCU features up to 16 self-capacitance or 64 mutual-capacitance electrodes, 30-cm proximity sensing, and high accuracy up to 1-fF detection. The MCUs also include four 16-bit timers, eUSCs that support UART, SPI, and I²C, a hardware multiplier, an RTC module with alarm capabilities, and a high-performance 10-bit ADC.

6.2 CPU

The MSP430™ CPU has a 16-bit RISC architecture that is highly transparent to the application. All operations, other than program-flow instructions, are performed as register operations in conjunction with seven addressing modes for source operand and four addressing modes for destination operand.

The CPU is integrated with 16 registers that provide reduced instruction execution time. The register-to-register operation execution time is one cycle of the CPU clock.

Four of the registers, R0 to R3, are dedicated as program counter (PC), stack pointer (SP), status register (SR), and constant generator (CG), respectively. The remaining registers are general-purpose registers.

Peripherals are connected to the CPU using data, address, and control buses. Peripherals can be handled with all instructions.

6.3 Operating Modes

The MSP430 has one active mode and several software-selectable low-power modes of operation (see [Table 6-1](#)). An interrupt event can wake the MCU from low-power mode LPM0 or LPM3, service the request, and restore the MCU back to the low-power mode on return from the interrupt program. Low-power modes LPM3.5 and LPM4.5 disable the core supply to minimize power consumption.

Table 6-1. Operating Modes

MODE		AM	LPM0	LPM3	LPM4	LPM3.5	LPM4.5
		ACTIVE MODE (FRAM ON)	CPU OFF	STANDBY	OFF	ONLY RTC	SHUTDOWN
Maximum system clock		16 MHz	16 MHz	40 kHz	0	40 kHz	0
Power consumption at 25°C, 3 V		126 µA/MHz	40 µA/MHz	1.7 µA/button average with 8-Hz scan	0.49 µA without SVS	0.73 µA with RTC counter only in LFXT	16 nA without SVS
Wake-up time		N/A	Instant	10 µs	10 µs	350 µs	350 µs
Wake-up events		N/A	All	All	I/O	RTC CapTIvate I/O	I/O
Power	Regulator	Full Regulation	Full Regulation	Partial Power Down	Partial Power Down	Partial Power Down	Power Down
	SVS	On	On	Optional	Optional	Optional	Optional
	Brownout	On	On	On	On	On	On

Table 6-1. Operating Modes (continued)

MODE		AM	LPM0	LPM3	LPM4	LPM3.5	LPM4.5
		ACTIVE MODE (FRAM ON)	CPU OFF	STANDBY	OFF	ONLY RTC	SHUTDOWN
Clock ⁽¹⁾	MCLK	Active	Off	Off	Off	Off	Off
	SMCLK	Optional	Optional	Off	Off	Off	Off
	FLL	Optional	Optional	Off	Off	Off	Off
	DCO	Optional	Optional	Off	Off	Off	Off
	MODCLK	Optional	Optional	Off	Off	Off	Off
	REFO	Optional	Optional	Optional	Off	Off	Off
	ACLK	Optional	Optional	Optional	Off	Off	Off
	XT1CLK	Optional	Optional	Optional	Off	Optional	Off
	VLOCLK	Optional	Optional	Optional	Off	Optional	Off
CapTivate MODCLK	Optional	Optional	Optional	Off	Off	Off	
Core	CPU	On	Off	Off	Off	Off	Off
	FRAM	On	On	Off	Off	Off	Off
	RAM	On	On	On	On	Off	Off
	Backup memory ⁽²⁾	On	On	On	On	On	Off
Peripherals	Timer0_A3	Optional	Optional	Optional	Off	Off	Off
	Timer1_A3	Optional	Optional	Optional	Off	Off	Off
	Timer2_A2	Optional	Optional	Optional	Off	Off	Off
	Timer3_A2	Optional	Optional	Optional	Off	Off	Off
	WDT	Optional	Optional	Optional	Off	Off	Off
	eUSCI_A0	Optional	Optional	Off	Off	Off	Off
	eUSCI_A1	Optional	Optional	Off	Off	Off	Off
	eUSCI_B0	Optional	Optional	Off	Off	Off	Off
	CRC	Optional	Optional	Off	Off	Off	Off
	ADC	Optional	Optional	Optional	Off	Off	Off
	RTC	Optional	Optional	Optional	Off	Optional	Off
CapTivate	Optional	Optional	Optional	Off	Off	Off	
I/O	General-purpose digital input/output	On	Optional	State Held	State Held	State Held	State Held

(1) The status shown for LPM4 applies to internal clocks only.

(2) Backup memory contains 32 bytes of register space in peripheral memory. See [Table 6-24](#) and [Table 6-43](#) for its memory allocation.

NOTE

XT1CLK and VLOCLK can be active during LPM4 if requested by low-frequency peripherals.

6.4 Interrupt Vector Addresses

The interrupt vectors and the power-up start address are in the address range 0FFFFh to 0FF80h. The vector contains the 16-bit address of the appropriate interrupt-handler instruction sequence.

Table 6-2. Interrupt Sources, Flags, and Vectors

INTERRUPT SOURCE	INTERRUPT FLAG	SYSTEM INTERRUPT	WORD ADDRESS	PRIORITY
System Reset Power up, Brownout, Supply supervisor External reset RST Watchdog time-out, Key violation FRAM uncorrectable bit error detection Software POR, BOR FLL unlock error	SVSHIFG PMMRSTIFG WDTIFG PMMPORIFG, PMMBORIFG SYSRSTIV FLLUNLOCKIFG	Reset	FFFEh	63, Highest
System NMI Vacant memory access JTAG mailbox FRAM access time error FRAM bit error detection	VMAIFG JMBINIFG, JMBOUTIFG CBDIFG, UBDIFG	Nonmaskable	FFFCh	62
User NMI External NMI Oscillator fault	NMIIFG OFIFG	Nonmaskable	FFFAh	61
Timer0_A3	TA0CCR0 CCIFG0	Maskable	FFF8h	60
Timer0_A3	TA0CCR1 CCIFG1, TA0CCR2 CCIFG2, TA0IFG (TA0IV)	Maskable	FFF6h	59
Timer1_A3	TA1CCR0 CCIFG0	Maskable	FFF4h	58
Timer1_A3	TA1CCR1 CCIFG1, TA1CCR2 CCIFG2, TA1IFG (TA1IV)	Maskable	FFF2h	57
Timer2_A2	TA2CCR0 CCIFG0	Maskable	FFF0h	56
Timer2_A2	TA2CCR1 CCIFG1, TA2IFG (TA2IV)		FFEEh	55
Timer3_A2	TA3CCR0 CCIFG0	Maskable	FFECh	54
Timer3_A2	TA3CCR1 CCIFG1, TA3IFG (TA3IV)		FFEAh	53
RTC	RTCIFG	Maskable	FFE8h	52
Watchdog timer interval mode	WDTIFG	Maskable	FFE6h	51
eUSCI_A0 receive or transmit	UCTXCPTIFG, UCSTTIFG, UCRXIFG, UCTXIFG (UART mode) UCRXIFG, UCTXIFG (SPI mode) (UCA0IV)	Maskable	FFE4h	50
eUSCI_A1 receive or transmit	UCTXCPTIFG, UCSTTIFG, UCRXIFG, UCTXIFG (UART mode) UCRXIFG, UCTXIFG (SPI mode) (UCA1IV)	Maskable	FFE2h	49
eUSCI_B0 receive or transmit	UCB0RXIFG, UCB0TXIFG (SPI mode) UCALIFG, UCNACKIFG, UCSTTIFG, UCSTPIFG, UCRXIFG0, UCTXIFG0, UCRXIFG1, UCTXIFG1, UCRXIFG2, UCTXIFG2, UCRXIFG3, UCTXIFG3, UCCNTIFG, UCBIT9IFG (I ² C mode) (UCB0IV)	Maskable	FFE0h	48
ADC	ADCIFG0, ADCINIFG, ADCLOIFG, ADCHIIFG, ADCTOVIFG, ADCOVIFG (ADCIV)	Maskable	FFDEh	47
P1	P1IFG.0 to P1IFG.7 (P1IV)	Maskable	FFDCh	46
P2	P2IFG.0 to P2IFG.7 (P2IV)	Maskable	FFDAh	45
CapTivate	(See CapTivate Design Center for details)	Maskable	FFD8h	44, Lowest
Reserved	Reserved	Maskable	FFD6h–FF88h	

Table 6-2. Interrupt Sources, Flags, and Vectors (continued)

INTERRUPT SOURCE	INTERRUPT FLAG	SYSTEM INTERRUPT	WORD ADDRESS	PRIORITY
Signatures	BSL Signature 2		0FF86h	
	BSL Signature 1		0FF84h	
	JTAG Signature 2		0FF82h	
	JTAG Signature 1		0FF80h	

6.5 Bootloader (BSL)

The BSL lets users program the FRAM or RAM using either the UART serial interface or the I²C interface. Access to the MCU memory through the BSL is protected by a user-defined password. Use of the BSL requires four pins (see [Table 6-3](#) and [Table 6-4](#)). The BSL entry requires a specific entry sequence on the $\overline{\text{RST}}$ /NMI/SBWDIO and TEST/SBWTCK pins. For the complete description of the feature of the BSL, see the *MSP430FR4xx and MSP430FR2xx Bootloader (BSL) User's Guide (SLAU610)*.

Table 6-3. UART BSL Pin Requirements and Functions

DEVICE SIGNAL	BSL FUNCTION
$\overline{\text{RST}}$ /NMI/SBWDIO	Entry sequence signal
TEST/SBWTCK	Entry sequence signal
P1.4	Data transmit
P1.5	Data receive
VCC	Power supply
VSS	Ground supply

Table 6-4. I²C BSL Pin Requirements and Functions

DEVICE SIGNAL	BSL FUNCTION
$\overline{\text{RST}}$ /NMI/SBWDIO	Entry sequence signal
TEST/SBWTCK	Entry sequence signal
P1.2	Data transmit and receive
P1.3	Clock
VCC	Power supply
VSS	Ground supply

6.6 JTAG Standard Interface

The MSP low-power microcontrollers support the standard JTAG interface, which requires four signals for sending and receiving data. The JTAG signals are shared with general-purpose I/O. The TEST/SBWTCK pin enables the JTAG signals. In addition to these signals, the $\overline{\text{RST}}/\text{NMI}/\text{SBWTDIO}$ is required to interface with MSP430 development tools and device programmers. [Table 6-5](#) lists the JTAG pin requirements. For further details on interfacing to development tools and device programmers, see the *MSP430 Hardware Tools User's Guide (SLAU278)*. For details on using the JTAG interface, see the *MSP430 Programming Via the JTAG Interface User's Guide (SLAU320)*.

Table 6-5. JTAG Pin Requirements and Function

DEVICE SIGNAL	DIRECTION	JTAG FUNCTION
P1.4/UCA0TXD/UCA0SIMO/TA1.2/TCK/A4/VREF+	IN	JTAG clock input
P1.5/UCA0RXD/UCA0SOMI/TA1.1/TMS/A5	IN	JTAG state control
P1.6/UCA0CLK/TA1CLK/TDI/TCLK/A6	IN	JTAG data input, TCLK input
P1.7/UCA0STE/SMCLK/TDO/A7	OUT	JTAG data output
TEST/SBWTCK	IN	Enable JTAG pins
$\overline{\text{RST}}/\text{NMI}/\text{SBWTDIO}$	IN	External reset
DVCC		Power supply
DVSS		Ground supply

6.7 Spy-Bi-Wire Interface (SBW)

The MSP low-power microcontrollers support the 2-wire SBW interface. SBW can be used to interface with MSP development tools and device programmers. [Table 6-6](#) lists the SBW interface pin requirements. For further details on interfacing to development tools and device programmers, see the *MSP430 Hardware Tools User's Guide (SLAU278)*. For details on using the SBW interface, see the *MSP430 Programming Via the JTAG Interface User's Guide (SLAU320)*.

Table 6-6. Spy-Bi-Wire Pin Requirements and Functions

DEVICE SIGNAL	DIRECTION	SBW FUNCTION
TEST/SBWTCK	IN	Spy-Bi-Wire clock input
$\overline{\text{RST}}/\text{NMI}/\text{SBWTDIO}$	IN, OUT	Spy-Bi-Wire data input and output
DVCC		Power supply
DVSS		Ground supply

6.8 FRAM

The FRAM can be programmed using the JTAG port, SBW, the BSL, or in-system by the CPU. Features of the FRAM include:

- Byte and word access capability
- Programmable wait state generation
- Error correction coding (ECC)

6.9 Memory Protection

The device features memory protection for user access authority and write protection, including options to:

- Secure the whole memory map to prevent unauthorized access from JTAG port or BSL, by writing JTAG and BSL signatures using the JTAG port, SBW, the BSL, or in-system by the CPU.
- Enable write protection to prevent unwanted write operation to FRAM contents by setting the control bits in the System Configuration 0 register. For detailed information, see the SYS chapter in the *MP430FR4xx and MP430FR2xx Family User's Guide (SLAU445)*.

6.10 Peripherals

Peripherals are connected to the CPU through data, address, and control buses. All peripherals can be handled by using all instructions in the memory map. For complete module description, see the *MP430FR4xx and MP430FR2xx Family User's Guide* (SLAU445).

6.10.1 Power-Management Module (PMM)

The PMM includes an integrated voltage regulator that supplies the core voltage to the device. The PMM also includes supply voltage supervisor (SVS) and brownout protection. The brownout reset circuit (BOR) is implemented to provide the proper internal reset signal to the device during power on and power off. The SVS circuitry detects if the supply voltage drops below a user-selectable safe level. SVS circuitry is available on the primary supply.

The device contains two on-chip reference: 1.5 V for internal reference and 1.2 V for external reference.

The 1.5-V reference is internally connected to ADC channel 13. DVCC is internally connected to ADC channel 15. When DVCC is set as the reference voltage for ADC conversion, the DVCC can be easily represent as [Equation 1](#) by using ADC sampling 1.5-V reference without any external components support.

$$DVCC = (1023 \times 1.5 \text{ V}) \div 1.5\text{-V reference ADC result} \quad (1)$$

A 1.2-V reference voltage can be buffered and output to P1.4/MCLK/TCK/A4/VREF+, when EXTREFEN = 1 in the PMMCTL1 register. ADC channel 4 can also be selected to monitor this voltage. For more detailed information, see the *MP430FR4xx and MP430FR2xx Family User's Guide* (SLAU445).

6.10.2 Clock System (CS) and Clock Distribution

The clock system includes a 32-kHz crystal oscillator (XT1), an internal very-low-power low-frequency oscillator (VLO), an integrated 32-kHz RC oscillator (REFO), an integrated internal digitally controlled oscillator (DCO) that may use frequency-locked loop (FLL) locking with internal or external 32-kHz reference clock, and an on-chip asynchronous high-speed clock (MODOSC). The clock system is designed for cost-effective designs with minimal external components. A fail-safe mechanism is included for XT1. The clock system module offers the following clock signals.

- **Main Clock (MCLK):** The system clock used by the CPU and all relevant peripherals accessed by the bus. All clock sources except MODOSC can be selected as the source with a predivider of 1, 2, 4, 8, 16, 32, 64, or 128.
- **Sub-Main Clock (SMCLK):** The subsystem clock used by the peripheral modules. SMCLK derives from the MCLK with a predivider of 1, 2, 4, or 8. This means SMCLK is always equal to or less than MCLK.
- **Auxiliary Clock (ACLK):** This clock is derived from the external XT1 clock or internal REFO clock up to 40 kHz.

All peripherals may have one or several clock sources depending on specific functionality. [Table 6-7](#) lists the clock distribution used in this device.

Table 6-7. Clock Distribution

	CLOCK SOURCE SELECT BITS	MCLK	SMCLK	ACLK	MODCLK	XT1CLK	VLOCLK	EXTERNAL PIN
Frequency Range		DC to 16 MHz	DC to 16 MHz	DC to 40 kHz	5 MHz ±10%	DC to 40 kHz	10 kHz ±50%	
CPU	N/A	Default						
FRAM	N/A	Default						
RAM	N/A	Default						
CRC	N/A	Default						
I/O	N/A	Default						
TA0	TASSEL		10b	01b				00b (TA0CLK pin)
TA1	TASSEL		10b	01b				00b (TA1CLK pin)
TA2	TASSEL		10b	01b				
TA3	TASSEL		10b	01b				
eUSCI_A0	UCSSEL		10b or 11b		01b			00b (UCA0CLK pin)
eUSCI_A1	UCSSEL		10b or 11b		01b			00b (UCA1CLK pin)
eUSCI_B0	UCSSEL		10b or 11b		01b			00b (UCB0CLK pin)
WDT	WDTSSEL		00b	01b			10b or 11b	
ADC	ADCSSEL		11b	01b	00b			
CapTlvate	CAPTSSEL			00b			01b	
	CAPCLKSEL		1b					
RTC	RTCSS		01b			10b	11b	

6.10.3 General-Purpose Input/Output Port (I/O)

Up to 19 I/O ports are implemented.

- P1 and P2 are full 8-bit ports; P3 has 3 bits implemented.
- All individual I/O bits are independently programmable.
- Any combination of input, output, and interrupt conditions is possible.
- Programmable pullup or pulldown on all ports.
- Edge-selectable interrupt and LPM3.5 and LPM4.5 wake-up input capability is available for P1 and P2.
- Read and write access to port-control registers is supported by all instructions.
- Ports can be accessed byte-wise or word-wise in pairs.
- CapTlvate functionality is supported on all CAPx.y pins.

NOTE

Configuration of digital I/Os after BOR reset

To prevent any cross currents during start-up of the device, all port pins are high-impedance with Schmitt triggers and module functions disabled. To enable the I/O functions after a BOR reset, the ports must be configured first and then the LOCKLPM5 bit must be cleared. For details, see the *Configuration After Reset* section in the Digital I/O chapter of the *MP430FR4xx and MP430FR2xx Family User's Guide (SLAU445)*

6.10.4 Watchdog Timer (WDT)

The primary function of the WDT module is to perform a controlled system restart after a software problem occurs. If the selected time interval expires, a system reset is generated. If the watchdog function is not needed in an application, the module can be configured as interval timer and can generate interrupts at selected time intervals. [Table 6-8](#) lists the system clocks that can be used to source the WDT.

Table 6-8. WDT Clocks

WDTSEL	NORMAL OPERATION (WATCHDOG AND INTERVAL TIMER MODE)
00	SMCLK
01	ACLK
10	VLOCLK
11	Reserved

6.10.5 System (SYS) Module

The SYS module handles many of the system functions within the device. These features include power-on reset (POR) and power-up clear (PUC) handling, NMI source selection and management, reset interrupt vector generators, bootloader entry mechanisms, and configuration management (device descriptors). The SYS module also includes a data exchange mechanism through SBW called a JTAG mailbox mail box that can be used in the application. [Table 6-9](#) summarizes the interrupts that are managed by the SYS module.

Table 6-9. System Module Interrupt Vector Registers

INTERRUPT VECTOR REGISTER	ADDRESS	INTERRUPT EVENT	VALUE	PRIORITY
SYSRSTIV, System Reset	015Eh	No interrupt pending	00h	
		Brownout (BOR)	02h	Highest
		RSTIFG RST/NMI (BOR)	04h	
		PMMSWBOR software BOR (BOR)	06h	
		LPMx.5 wake up (BOR)	08h	
		Security violation (BOR)	0Ah	
		Reserved	0Ch	
		SVSHIFG SVSH event (BOR)	0Eh	
		Reserved	10h	
		Reserved	12h	
		PMMSWPOR software POR (POR)	14h	
		WDTIFG watchdog time-out (PUC)	16h	
		WDTPW password violation (PUC)	18h	
		FRCTLPW password violation (PUC)	1Ah	
		Uncorrectable FRAM bit error detection	1Ch	
		Peripheral area fetch (PUC)	1Eh	
		PMMPW PMM password violation (PUC)	20h	
		FLL unlock (PUC)	24h	
Reserved	22h, 26h to 3Eh	Lowest		
SYSSNIV, System NMI	015Ch	No interrupt pending	00h	
		SVS low-power reset entry	02h	Highest
		Uncorrectable FRAM bit error detection	04h	
		Reserved	06h	
		Reserved	08h	
		Reserved	0Ah	
		Reserved	0Ch	
		Reserved	0Eh	
		Reserved	10h	
		VMAIFG Vacant memory access	12h	
		JMBINIFG JTAG mailbox input	14h	
		JMBOUTIFG JTAG mailbox output	16h	
		Correctable FRAM bit error detection	18h	
		Reserved	1Ah to 1Eh	Lowest
SYSUNIV, User NMI	015Ah	No interrupt pending	00h	
		NMIIFG NMI pin or SVS _H event	02h	Highest
		OFIFG oscillator fault	04h	
		Reserved	06h to 1Eh	Lowest

6.10.6 Cyclic Redundancy Check (CRC)

The 16-bit cyclic redundancy check (CRC) module produces a signature based on a sequence of data values and can be used for data checking purposes. The CRC generation polynomial is compliant with CRC-16-CCITT standard of $x^{16} + x^{12} + x^5 + 1$.

6.10.7 Enhanced Universal Serial Communication Interface (eUSCI_A0, eUSCI_B0)

The eUSCI modules are used for serial data communications. The eUSCI_A module supports either UART or SPI communications. The eUSCI_B module supports either SPI or I²C communications. Additionally, eUSCI_A supports automatic baud-rate detection and IrDA. [Table 6-10](#) lists the pin configurations that are required for each eUSCI mode.

Table 6-10. eUSCI Pin Configurations

	PIN	UART	SPI
eUSCI_A0	P1.4	TXD	SIMO
	P1.5	RXD	SOMI
	P1.6	–	SCLK
	P1.7	–	STE
eUSCI_A1	P2.6	TXD	SIMO
	P2.5	RXD	SOMI
	P2.4	–	SCLK
	P3.1	–	STE
	PIN	I ² C	SPI
eUSCI_B0	P1.0	–	STE
	P1.1	–	SCLK
	P1.2	SDA	SIMO
	P1.3	SCL	SOMI

6.10.8 Timers (Timer0_A3, Timer1_A3, Timer2_A2 and Timer3_A2)

The Timer0_A3 and Timer1_A3 modules are 16-bit timers and counters with three capture/compare registers each. Each timer supports multiple captures or compares, PWM outputs, and interval timing (see [Table 6-11](#) and [Table 6-12](#)). Each timer has extensive interrupt capabilities. Interrupts may be generated from the counter on overflow conditions and from each of the capture/compare registers. The CCR0 registers on both Timer0_A3 and Timer1_A3 are not externally connected and can only be used for hardware period timing and interrupt generation. In Up mode, they can be used to set the overflow value of the counter.

Table 6-11. Timer0_A3 Signal Connections

PORT PIN	DEVICE INPUT SIGNAL	MODULE INPUT NAME	MODULE BLOCK	MODULE OUTPUT SIGNAL	DEVICE OUTPUT SIGNAL			
P1.0	TA0CLK	TACLK	Timer	N/A				
	ACLK (internal)	ACLK						
	SMCLK (internal)	SMCLK						
		CCI0A	CCR0	TA0				
		CCI0B			Timer1_A3 CCI0B input			
	DVSS	GND						
	DVCC	VCC						
	P1.1	TA0.1			CCI1A	CCR1	TA1	TA0.1
		from RTC (internal)			CCI1B			Timer1_A3 CCI1B input
DVSS		GND						
	DVCC	VCC						
P1.2	TA0.2	CCI2A	CCR2	TA2	TA0.2			
		CCI2B			Timer1_A3 CCI2B input, IR Input			
	DVSS	GND						
	DVCC	VCC						

Table 6-12. Timer1_A3 Signal Connections

PORT PIN	DEVICE INPUT SIGNAL	MODULE INPUT NAME	MODULE BLOCK	MODULE OUTPUT SIGNAL	DEVICE OUTPUT SIGNAL
P1.6	TA1CLK	TACLK	Timer	N/A	
	ACLK (internal)	ACLK			
	SMCLK (internal)	SMCLK			
		CCI0A	CCR0	TA0	
	Timer0_A3 CCR0B output (internal)	CCI0B			
	DVSS	GND			
	DVCC	VCC			
P1.5	TA1.1	CCI1A	CCR1	TA1	TA1.1
	Timer0_A3 CCR1B output (internal)	CCI1B			to ADC trigger
	DVSS	GND			
	DVCC	VCC			
P1.4	TA1.2	CCI2A	CCR2	TA2	TA1.2
	Timer0_A3 CCR2B output (internal)	CCI2B			IR Input
	DVSS	GND			
	DVCC	VCC			

The interconnection of Timer0_A3 and Timer1_A3 can be used to modulate the eUSCI_A pin of UCA0TXD/UCA0SIMO in either ASK or FSK mode, with which a user can easily acquire a modulated infrared command for directly driving an external IR diode. The IR functions are fully controlled by SYS configuration registers 1 including IREN (enable), IRPSEL (polarity select), IRMSEL (mode select), IRDSEL (data select), and IRDATA (data) bits. For more information, see the SYS chapter in the *MP430FR4xx and MP430FR2xx Family User's Guide (SLAU445)*.

The Timer2_A2 and Timer3_A2 modules are 16-bit timers and counters with two capture/compare registers each. Each timer supports multiple captures or compares and interval timing (see [Table 6-13](#) and [Table 6-14](#)). Each timer has extensive interrupt capabilities. Interrupts may be generated from the counter on overflow conditions and from each of the capture registers. The CCR0 registers on both Timer2_TA2 and Timer3_TA2 are not externally connected and can only be used for hardware period timing and interrupt generation. In Up mode, they can be used to set the overflow value of the counter. The Timer2_A2 and Timer3_A2 are only internal connected and do not support PWM output.

Table 6-13. Timer2_A2 Signal Connections

DEVICE INPUT SIGNAL	MODULE INPUT NAME	MODULE BLOCK	MODULE OUTPUT SIGNAL	DEVICE OUTPUT SIGNAL	
ACLK (internal)	ACLK	Timer	N/A		
SMCLK (internal)	SMCLK				
		CCR0	TA0		
				CCI0A	
				CCI0B	Timer3_A3 CCI0B input
	DVSS			GND	
	DVCC			VCC	
		CCR1	CCR1		
				CCI1A	
				CCI1B	Timer3_A3 CCI1B input
	DVSS			GND	
DVCC	VCC				

Table 6-14. Timer3_A2 Signal Connections

DEVICE INPUT SIGNAL	MODULE INPUT NAME	MODULE BLOCK	MODULE OUTPUT SIGNAL	DEVICE OUTPUT SIGNAL
ACLK (internal)	ACLK	Timer	N/A	
SMCLK (internal)	SMCLK			
	CCI0A	CCR0	TA0	
Timer3_A3 CCI0B input	CCI0B			
DVSS	GND			
DVCC	VCC			
	CCI1A	CCR1	CCR1	
Timer3_A3 CCI1B input	CCI1B			
DVSS	GND			
DVCC	VCC			

6.10.9 Hardware Multiplier (MPY)

The multiplication operation is supported by a dedicated peripheral module. The module performs operations with 32-, 24-, 16-, and 8-bit operands. The MPY module supports signed multiplication, unsigned multiplication, signed multiply-and-accumulate, and unsigned multiply-and-accumulate operations.

6.10.10 Backup Memory (BKMEM)

The BKMEM supports data retention during LPM3.5. This device provides up to 32 bytes that are retained during LPM3.5.

6.10.11 Real-Time Clock (RTC)

The RTC is a 16-bit modulo counter that is functional in AM, LPM0, LPM3, and LPM3.5. This module may periodically wake up the CPU from LPM0, LPM3 and LPM3.5 based on timing from a low-power clock source such as the XT1 and VLO clocks. In AM, RTC can be driven by SMCLK to generate high-frequency timing events and interrupts. The RTC overflow events trigger:

- Timer0_A3 CCR1B
- ADC conversion trigger when ADCSHSx bits are set as 01b

6.10.12 10-Bit Analog-to-Digital Converter (ADC)

The 10-bit ADC module supports fast 10-bit analog-to-digital conversions with single-ended input. The module implements a 10-bit SAR core, sample select control, reference generator and a conversion result buffer. A window comparator with lower and upper limits allows CPU-independent result monitoring with three window comparator interrupt flags.

The ADC supports 10 external inputs and 4 internal inputs (see [Table 6-15](#)).

Table 6-15. ADC Channel Connections

ADC _{SHSx}	ADC CHANNELS	EXTERNAL PINOUT
0	A0/V _{ref} +	P1.0
1	A1	P1.1
2	A2/V _{ref} -	P1.2
3	A3	P1.3
4	A4 ⁽¹⁾	P1.4
5	A5	P1.5
6	A6	P1.6
7	A7	P1.7
8	A8	NA
9	A9	NA
10	Not used	N/A
11	Not used	N/A
12	On-chip temperature sensor	N/A
13	Reference voltage (1.5 V)	N/A
14	DVSS	N/A
15	DVCC	N/A

(1) When A4 is used, the PMM 1.2-V reference voltage can be output to this pin by setting the PMM control register. The 1.2-V voltage can be directly measured by A4 channel.

The analog-to-digital conversion can be started by software or a hardware trigger. [Table 6-16](#) lists the trigger sources that are available.

Table 6-16. ADC Trigger Signal Connections

ADCINCH _x		TRIGGER SOURCE
BINARY	DECIMAL	
00	0	ADCSC bit (software trigger)
01	1	RTC event
10	2	TA1.1B
11	3	TA1.2B

6.10.13 CapTivate

The CapTivate module detects the capacitance changed with a charge-transfer method and is functional in AM, LPM0, and LPM3. The CapTivate module can periodically wake the CPU from LPM0 or LPM3 based on a timer source such as the ACLK and VLO clocks. The CapTivate module supports the following touch-sensing capability:

- Up to 64 CapTivate sense channels composed of 4 CapTivate blocks. Each block consists of 4 I/Os, and these blocks scan in parallel of 4 electrodes.
- Each block can be individually configured in self or mutual mode. Each CapTivate I/O can be used for either self or mutual electrodes.
- Supports a wake-on-touch state machine.
- Supports synchronized conversion on a zero-crossing event trigger.
- Processing logic to perform filter calculation and threshold detection.

6.10.14 Embedded Emulation Module (EEM)

The EEM supports real-time in-system debugging. The EEM on these devices has the following features:

- Three hardware triggers or breakpoints on memory access
- One hardware trigger or breakpoint on CPU register write access
- Up to four hardware triggers can be combined to form complex triggers or breakpoints
- One cycle counter
- Clock control on module level
- EEM version: S

6.11 Input/Output Schematics

6.11.1 Port P1 Input/Output With Schmitt Trigger

Figure 6-1 shows the port schematic. Table 6-17 summarizes the selection of pin function.

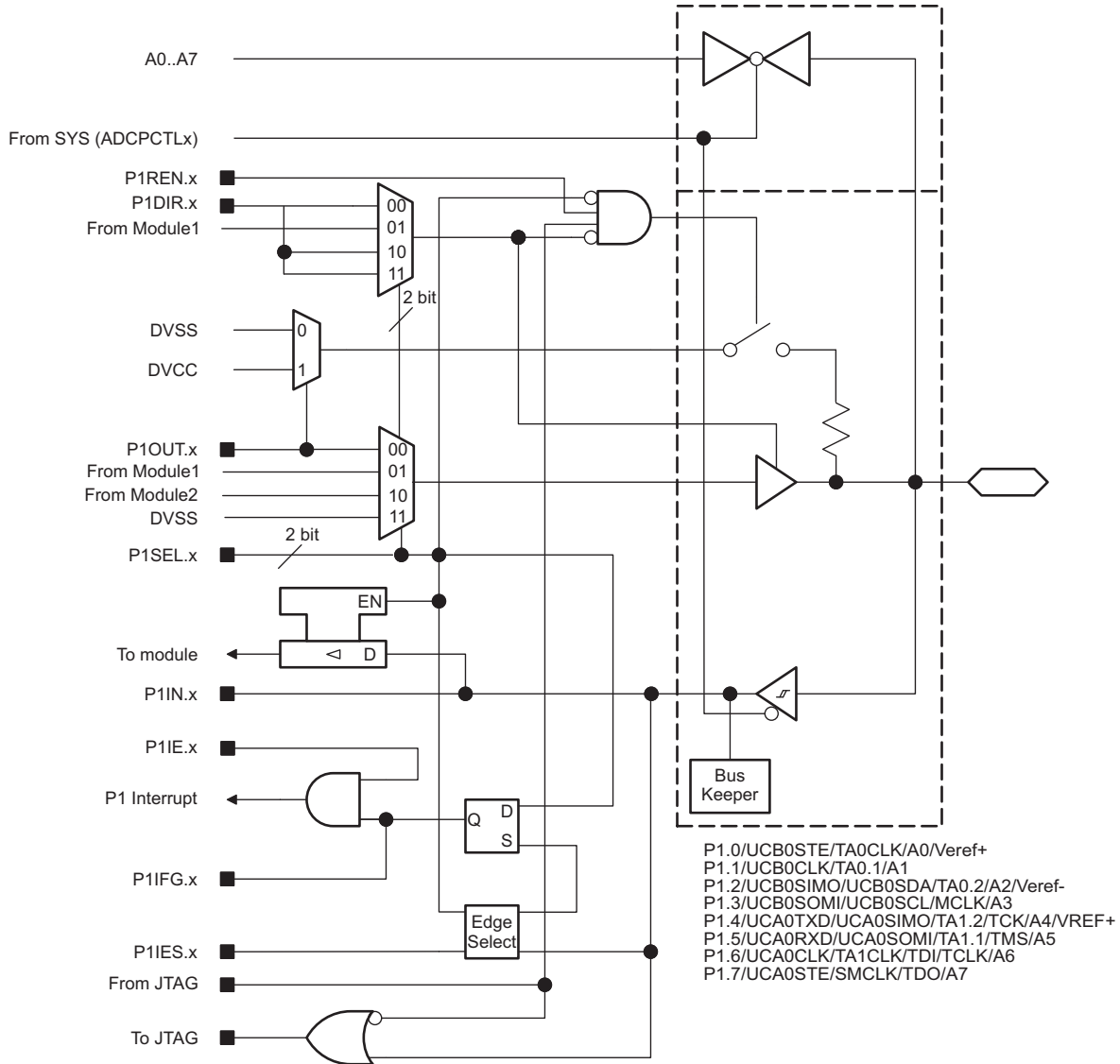

Figure 6-1. Port P1 (P1.0 to P1.7) Input/Output With Schmitt Trigger

Table 6-17. Port P1 (P1.0 to P1.7) Pin Functions

PIN NAME (P1.x)	x	FUNCTION	CONTROL BITS AND SIGNALS ⁽¹⁾			
			P1DIR.x	P1SELx	ADCPCTLx ⁽²⁾	JTAG
P1.0/UCB0STE/ TA0CLK/A0	0	P1.0 (I/O)	I: 0; O: 1	00	0	N/A
		UCB0STE	X	01	0	N/A
		TA0CLK	0	10	0	N/A
		A0/Veref+	X	X	1 (x = 0)	N/A
P1.1/UCB0CLK/TA0.1/ A1	1	P1.1 (I/O)	I: 0; O: 1	00	0	N/A
		UCB0CLK	X	01	0	N/A
		TA0.CCI1A	0	10	0	N/A
		TA0.1	1			
		A1	X	X	1 (x = 1)	N/A
P1.2/UCB0SIMO/ UCB0SDA/TA0.2/A2	2	P1.2 (I/O)	I: 0; O: 1	00	0	N/A
		UCB0SIMO/UCB0SDA	X	01	0	N/A
		TA0.CCI2A	0	10	0	N/A
		TA0.2	1			
		A2/Veref-	X	X	1 (x = 2)	N/A
P1.3/UCB0SOMI/ UCB0SCL/MCLK/A3	3	P1.3 (I/O)	I: 0; O: 1	00	0	N/A
		UCB0SOMI/UCB0SCL	X	01	0	N/A
		MCLK	1	10	0	N/A
		A3	X	X	1 (x = 3)	N/A
P1.4/UCA0TXD/ UCA0SIMO/TA1.2/TCK/ A4 /VREF+	4	P1.4 (I/O)	I: 0; O: 1	00	0	Disabled
		UCA0TXD/UCA0SIMO	X	01	0	Disabled
		TA1.CCI2A	0	10	0	Disabled
		TA1.2	1			
		A4, VREF+	X	X	1 (x = 4)	Disabled
		JTAG TCK	X	X	X	TCK
P1.5/UCA0RXD/ UCA0SOMI/TA1.1/TMS/ A5	5	P1.5 (I/O)	I: 0; O: 1	00	0	Disabled
		UCA0RXD/UCA0SOMI	X	01	0	Disabled
		TA1.CCI1A	0	10	0	Disabled
		TA1.1	1			
		A5	X	X	1 (x = 5)	Disabled
		JTAG TMS	X	X	X	TMS
P1.6/UCA0CLK/ TA1CLK/TDI/TCLK/A6	6	P1.6 (I/O)	I: 0; O: 1	00	0	Disabled
		UCA0CLK	X	01		Disabled
		TA1CLK	0	10	0	Disabled
		A6	X	X	1 (x = 6)	Disabled
		JTAG TDI/TCLK	X	X	X	TDI/TCLK
P1.7/UCA0STE/SMCLK/ TDO/A7	7	P1.7 (I/O)	I: 0; O: 1	00	0	Disabled
		UCA0STE	X	01	0	Disabled
		SMCLK	1	10	0	Disabled
		A7	X	X	1 (x = 7)	Disabled
		JTAG TDO	X	X	X	TDO

(1) X = don't care

(2) Setting the ADCPCTLx bit in SYSCFG2 register disables both the output driver and input Schmitt trigger to prevent leakage when analog signals are applied.

6.11.2 Port P2 (P2.0 to P2.2) Input/Output With Schmitt Trigger

Figure 6-2 shows the port schematic. Table 6-18 summarizes the selection of pin function.

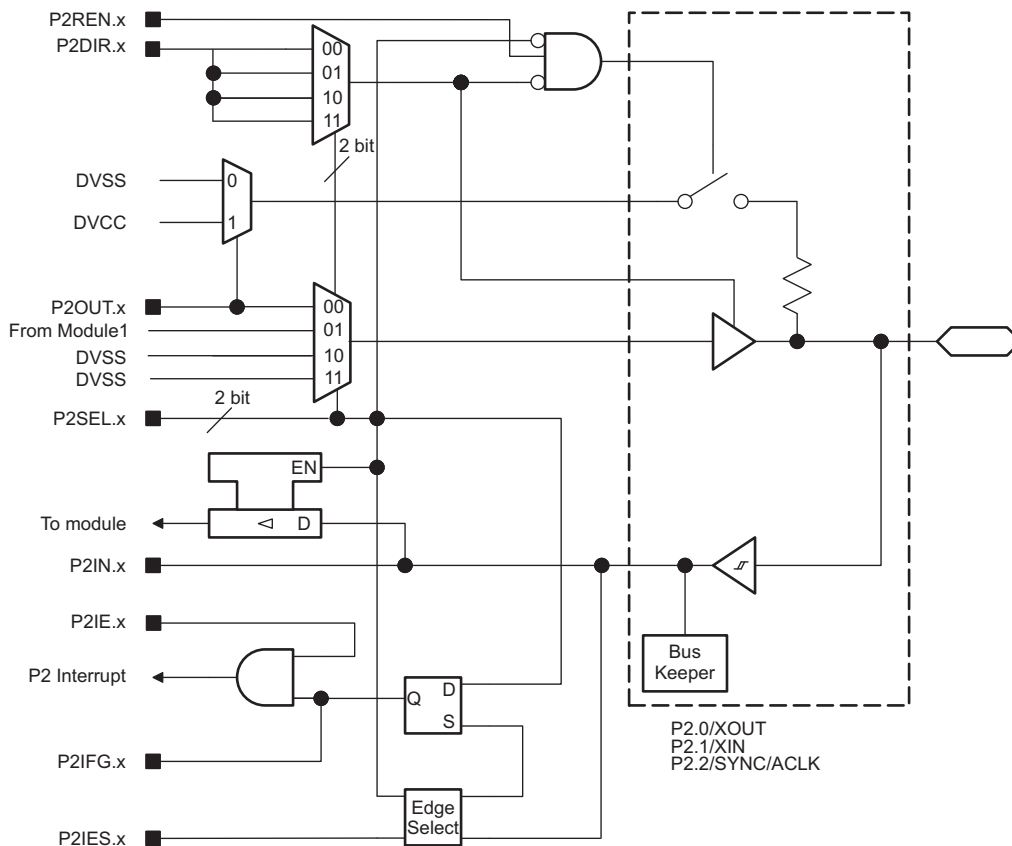

Figure 6-2. Port P2 (P2.0 to P2.2) Input/Output With Schmitt Trigger

Table 6-18. Port P2 (P2.0 to P2.2) Pin Functions

PIN NAME (P2.x)	x	FUNCTION	CONTROL BITS AND SIGNALS ⁽¹⁾	
			P2DIR.x	P2SELx
P2.0/XOUT	0	P2.0 (I/O)	I: 0; O: 1	00
		XOUT	1	01
P2.1/XIN	1	P2.1 (I/O)	I: 0; O: 1	00
		XIN	0	01
P2.2/SYNC/ACLK	2	P2.2 (I/O)	I: 0; O: 1	00
		SYNC	0	01
		ACLK	1	10

(1) X = don't care

6.11.3 Port P2 (P2.3 to P2.7) Input/Output With Schmitt Trigger

Figure 6-3 shows the port schematic. Table 6-19 summarizes the selection of pin function.

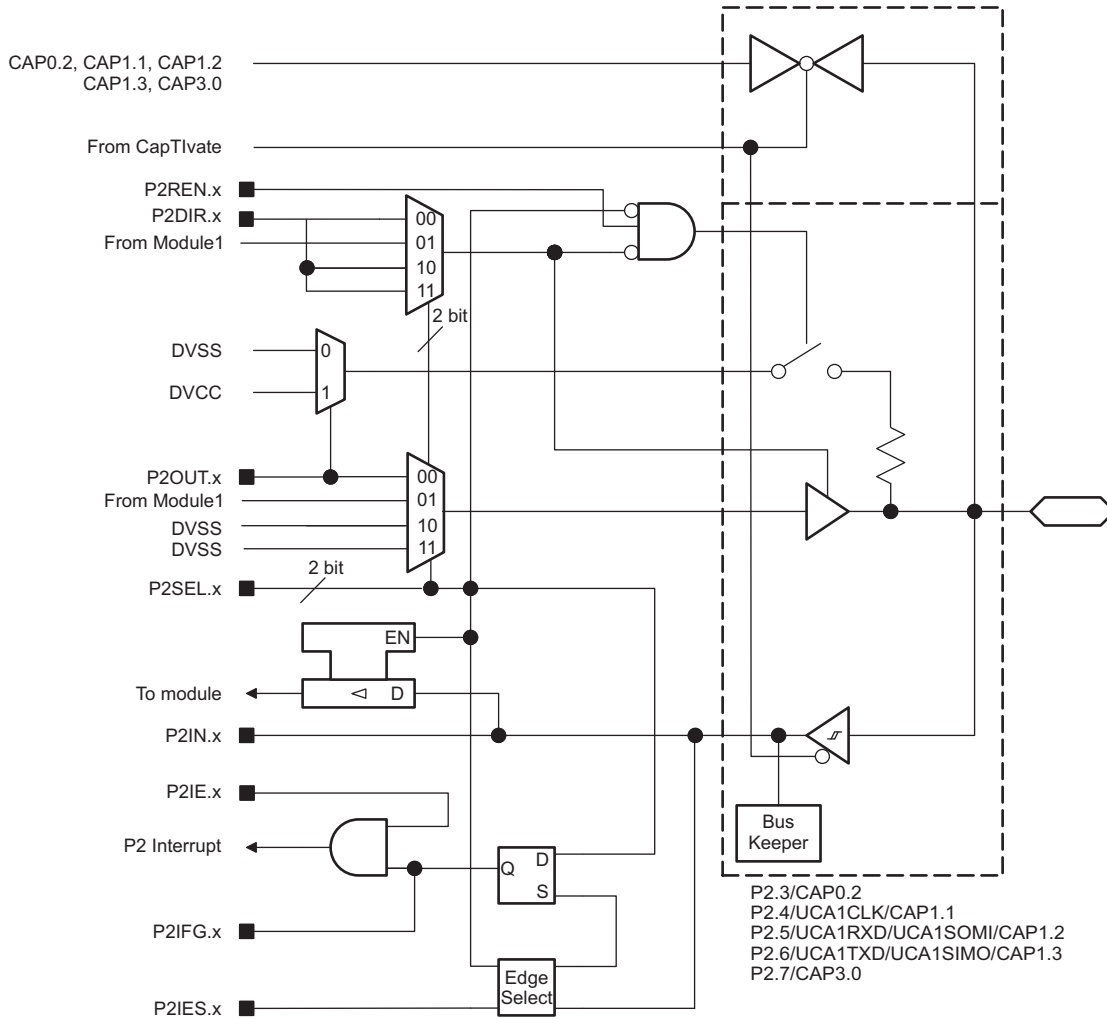

Figure 6-3. Port P2 (P2.3 to P2.7) Input/Output With Schmitt Trigger

Table 6-19. Port P2 (P2.3 to P2.7) Pin Functions

PIN NAME (P2.x)	x	FUNCTION	CONTROL BITS AND SIGNALS ⁽¹⁾		
			P2DIR.x	P2SELx	ANALOG FUNCTION
P2.3/CAP0.2	3	P2.3 (I/O)	I: 0; O: 1	00	0
		CAP0.2	X	X	1
P2.4/UCA1CLK/ CAP1.1	4	P2.4 (I/O)	I: 0; O: 1	00	0
		UCA1CLK	X	01	0
		CAP1.1	X	X	1
P2.5/UCA1RXD/ UCA1SOMI/CAP1.2	5	P2.5 (I/O)	I: 0; O: 1	00	0
		UCA1RXD/UCA1SOMI	X	01	0
		CAP1.2	X	X	1
P2.6/UCA1TXD/ UCA1SIMO/CAP1.3	6	P2.6 (I/O)	I: 0; O: 1	00	0
		UCA1TXD/UCA1SIMO	X	01	0
		CAP1.3	X	X	1
P2.7/CAP3.0	7	P2.7 (I/O)	I: 0; O: 1	0	0
		CAP3.0	X	X	1

(1) X = don't care

6.11.4 Port P3 (P3.0 to P3.2) Input/Output With Schmitt Trigger

Figure 6-4 shows the port schematic. Table 6-20 summarizes the selection of pin function.

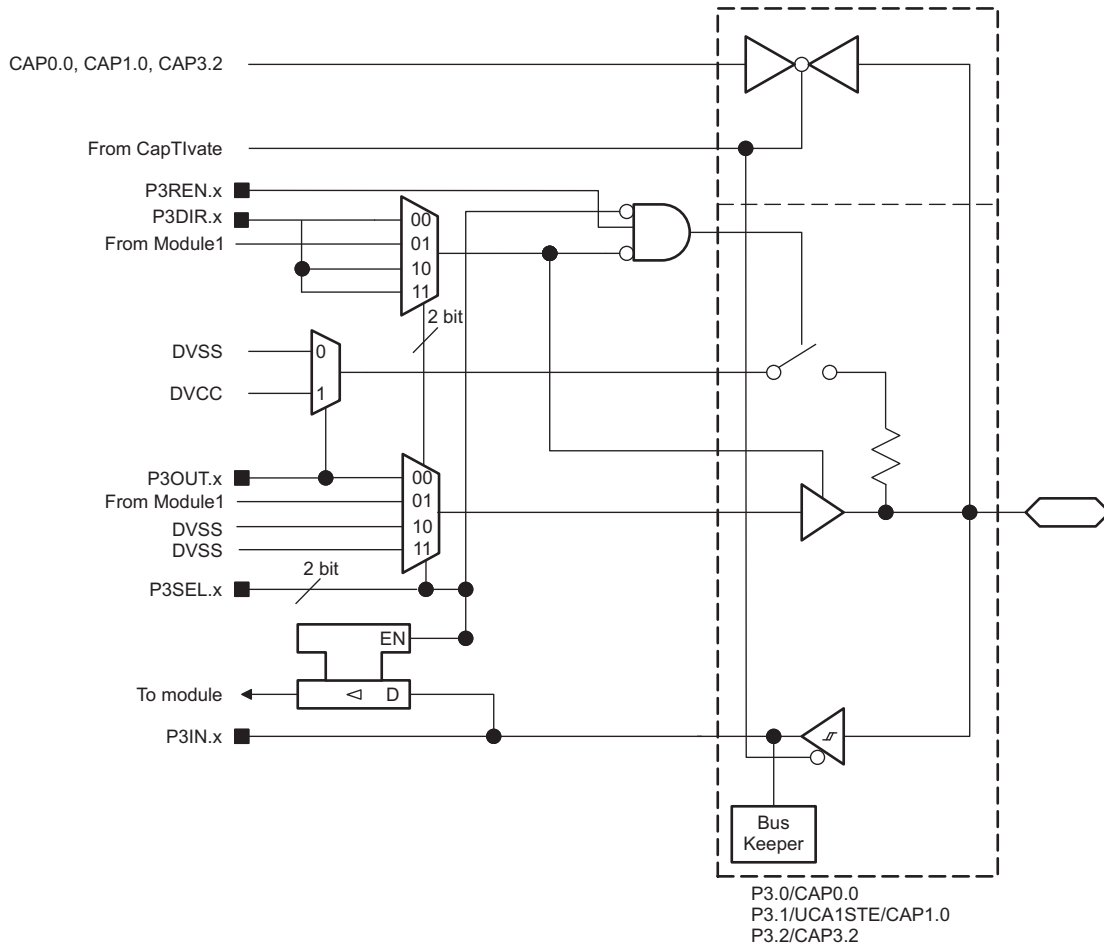

Figure 6-4. Port P3 (P3.0 to P3.2) Input/Output With Schmitt Trigger

NOTE

CapTIvate shared with I/Os configuration

The CapTIvate function and GPIOs are powered by different power supplies (1.5 V and 3.3 V, respectively).

To prevent pad damage when changing the function, TI recommends checking the external application circuit of each pad before enabling the alternate function.

Table 6-20. Port P3 (P3.0 to P3.2) Pin Functions

PIN NAME (P3.x)	x	FUNCTION	CONTROL BITS AND SIGNALS ⁽¹⁾		
			P3DIR.x	P3SEL.x	ANALOG FUNCTION
P3.0/CAP0.0	0	P3.0 (I/O)	I: 0; O: 1	00	0
		CAP0.0	X	X	1
P3.1/UCA1STE/ CAP1.0	1	P3.1 (I/O)	I: 0; O: 1	00	0
		UCA1STE	X	01	0
		CAP1.0	X	X	1
P3.2/CAP3.2	2	P3.2 (I/O)	I: 0; O: 1	00	0
		CAP3.2	X	X	1

(1) X = don't care

6.12 Device Descriptors

Table 6-21 lists the Device IDs of the devices. Table 6-22 lists the contents of the device descriptor tag-length-value (TLV) structure for the devices.

Table 6-21. Device IDs

DEVICE	DEVICE ID	
	1A05h	1A04h
MSP430FR2633	82h	3Ch
MSP430FR2533	82h	3Dh
MSP430FR2632	82h	3Eh
MSP430FR2532	82h	3Fh

Table 6-22. Device Descriptors

DESCRIPTION		MSP430FR2633, MSP430FR2632, MSP430FR2533, MSP430FR2532	
		ADDRESS	VALUE
Information Block	Info length	1A00h	06h
	CRC length	1A01h	06h
	CRC value ⁽¹⁾	1A02h	per unit
		1A03h	per unit
	Device ID	1A04h	See Table 6-21
		1A05h	
	Hardware revision	1A06h	per unit
Firmware revision	1A07h	per unit	
Die Record	Die record tag	1A08h	08h
	Die record length	1A09h	0Ah
	Lot wafer ID	1A0Ah	per unit
		1A0Bh	per unit
		1A0Ch	per unit
		1A0Dh	per unit
	Die X position	1A0Eh	per unit
		1A0Fh	per unit
	Die Y position	1A10h	per unit
		1A11h	per unit
Test result	1A12h	per unit	
	1A13h	per unit	
ADC Calibration	ADC calibration tag	1A14h	per unit
	ADC calibration length	1A15h	per unit
	ADC gain factor	1A16h	per unit
		1A17h	per unit
	ADC offset	1A18h	per unit
		1A19h	per unit
	ADC 1.5-V reference temperature 30°C	1A1Ah	per unit
		1A1Bh	per unit
ADC 1.5-V reference temperature 85°C	1A1Ch	per unit	
	1A1Dh	per unit	

(1) The CRC value covers the check sum from 0x1A04h to 0x1AEFh by applying the CRC-CCITT-16 polynomial of $x^{16} + x^{12} + x^5 + 1$.

Table 6-22. Device Descriptors (continued)

DESCRIPTION		MSP430FR2633, MSP430FR2632, MSP430FR2533, MSP430FR2532	
		ADDRESS	VALUE
Reference and DCO Calibration	Calibration tag	1A1Eh	12h
	Calibration length	1A1Fh	04h
	1.5-V reference factor	1A20h	per unit
		1A21h	per unit
	DCO tap setting for 16 MHz, temperature 30°C ⁽²⁾	1A22h	per unit
1A23h		per unit	

(2) This value can be directly loaded into DCO bits in CSCTL0 registers to get accurate 16-MHz frequency at room temperature, especially when the MCU exits from LPM3 and below. TI suggests using the predivider to decrease the frequency if the temperature drift might result an overshoot beyond 16 MHz.

6.13 Memory

6.13.1 Memory Organization

Table 6-23 summarizes the memory organization of the devices.

Table 6-23. Memory Organization

	ACCESS	MSP430FR2633	MSP430FR2632	MSP430FR2533	MSP430FR2532
Memory (FRAM) Main: interrupt vectors and signatures Main: code memory	Read/Write (Optional Write Protect) ⁽¹⁾	15KB FFFFh–FF80h FFFFh–C400h	8KB FFFFh–FF80h FFFFh–E000h	15KB FFFFh–FF80h FFFFh–C400h	8KB FFFFh–FF80h FFFFh–E000h
RAM	Read/Write	4KB 2FFFh–2000h	2KB 27FFh–2000h	2KB 27FFh–2000h	1KB 23FFh–2000h
Information Memory (FRAM)	Read/Write (Optional Write Protect) ⁽²⁾	512B 19FFh–1800h	512B 19FFh–1800h	512B 19FFh–1800h	512B 19FFh–1800h
Bootstrap loader (BSL1) Memory (ROM)	Read only	2KB 17FFh–1000h	2KB 17FFh–1000h	2KB 17FFh–1000h	2KB 17FFh–1000h
Bootstrap loader (BSL2) Memory (ROM)	Read only	1KB FFFFh–FFC00h	1KB FFFFh–FFC00h	1KB FFFFh–FFC00h	1KB FFFFh–FFC00h
CapTivate Libraries and Driver Libraries (ROM)	Read only	12KB 6FFFh–4000h	12KB 6FFFh–4000h	12KB 6FFFh–4000h	12KB 6FFFh–4000h
Peripherals	Read/Write	4KB 0FFFh–0000h	4KB 0FFFh–0000h	4KB 0FFFh–0000h	4KB 0FFFh–0000h

(1) The Program FRAM can be write protected by setting PFWP bit in SYSCFG0 register. See the SYS chapter in *MSP430FR2633 Family User's Guide (SLAU445)* for more details

(2) The Information FRAM can be write protected by setting DFWP bit in SYSCFG0 register. See the SYS chapter in *MSP430FR2633 Family User's Guide (SLAU445)* for more details

6.13.2 Peripheral File Map

Table 6-24 lists the available peripherals and the register base address for each. Table 6-25 through list the registers and address offsets for each peripheral.

Table 6-24. Peripherals Summary

MODULE NAME	BASE ADDRESS	SIZE
Special Functions (See Table 6-25)	0100h	0010h
PMM (See Table 6-26)	0120h	0020h
SYS (See Table 6-27)	0140h	0040h
CS (See Table 6-28)	0180h	0020h
FRAM (See Table 6-29)	01A0h	0010h
CRC (See Table 6-30)	01C0h	0008h
WDT (See Table 6-31)	01CCh	0002h
Port P1, P2 (See Table 6-32)	0200h	0020h
Port P3 (See Table 6-33)	0220h	0020h
RTC (See Table 6-34)	0300h	0010h
Timer0_A3 (See Table 6-35)	0380h	0030h
Timer1_A3 (See Table 6-36)	03C0h	0030h
Timer2_A2 (See Table 6-37)	0400h	0030h
Timer3_A2 (See Table 6-38)	0440h	0030h
MPY32 (See Table 6-39)	04C0h	0030h
eUSCI_A0 (See Table 6-40)	0500h	0020h
eUSCI_A1 (See Table 6-41)	0520h	0020h
eUSCI_B0 (See Table 6-42)	0540h	0030h
Backup Memory (See Table 6-43)	0660h	0020h
ADC (See Table 6-44)	0700h	0040h
CapTivate (See CapTivate Design Center for details)	0A00h	0200h

Table 6-25. Special Function Registers (Base Address: 0100h)

REGISTER DESCRIPTION	ACRONYM	OFFSET
SFR interrupt enable	SFRIE1	00h
SFR interrupt flag	SFRIFG1	02h
SFR reset pin control	SFRRPCR	04h

Table 6-26. PMM Registers (Base Address: 0120h)

REGISTER DESCRIPTION	ACRONYM	OFFSET
PMM control 0	PMMCTL0	00h
PMM control 1	PMMCTL1	02h
PMM control 2	PMMCTL2	04h
PMM interrupt flags	PMMIFG	0Ah
PM5 control 0	PM5CTL0	10h

Table 6-27. SYS Registers (Base Address: 0140h)

REGISTER DESCRIPTION	ACRONYM	OFFSET
System control	SYSCTL	00h
Bootloader configuration area	SYSBSLC	02h
JTAG mailbox control	SYSJMBC	06h
JTAG mailbox input 0	SYSJMBI0	08h
JTAG mailbox input 1	SYSJMBI1	0Ah
JTAG mailbox output 0	SYSJMBO0	0Ch
JTAG mailbox output 1	SYSJMBO1	0Eh
Bus error vector generator	SYSBERRIV	18h
User NMI vector generator	SYSUNIV	1Ah
System NMI vector generator	SYSSNIV	1Ch
Reset vector generator	SYSRSTIV	1Eh
System configuration 0	SYSCFG0	20h
System configuration 1	SYSCFG1	22h
System configuration 2	SYSCFG2	24h

Table 6-28. CS Registers (Base Address: 0180h)

REGISTER DESCRIPTION	ACRONYM	OFFSET
CS control 0	CSCTL0	00h
CS control 1	CSCTL1	02h
CS control 2	CSCTL2	04h
CS control 3	CSCTL3	06h
CS control 4	CSCTL4	08h
CS control 5	CSCTL5	0Ah
CS control 6	CSCTL6	0Ch
CS control 7	CSCTL7	0Eh
CS control 8	CSCTL8	10h

Table 6-29. FRAM Registers (Base Address: 01A0h)

REGISTER DESCRIPTION	ACRONYM	OFFSET
FRAM control 0	FRCTL0	00h
General control 0	GCCTL0	04h
General control 1	GCCTL1	06h

Table 6-30. CRC Registers (Base Address: 01C0h)

REGISTER DESCRIPTION	ACRONYM	OFFSET
CRC data input	CRC16DI	00h
CRC data input reverse byte	CRCDIRB	02h
CRC initialization and result	CRCINIRES	04h
CRC result reverse byte	CRCRESR	06h

Table 6-31. WDT Registers (Base Address: 01CCh)

REGISTER DESCRIPTION	ACRONYM	OFFSET
Watchdog timer control	WDTCTL	00h

Table 6-32. Port P1, P2 Registers (Base Address: 0200h)

REGISTER DESCRIPTION	ACRONYM	OFFSET
Port P1 input	P1IN	00h
Port P1 output	P1OUT	02h
Port P1 direction	P1DIR	04h
Port P1 pulling enable	P1REN	06h
Port P1 selection 0	P1SEL0	0Ah
Port P1 selection 1	P1SEL1	0Ch
Port P1 interrupt vector word	P1IV	0Eh
Port P1 interrupt edge select	P1IES	18h
Port P1 interrupt enable	P1IE	1Ah
Port P1 interrupt flag	P1IFG	1Ch
Port P2 input	P2IN	01h
Port P2 output	P2OUT	03h
Port P2 direction	P2DIR	05h
Port P2 pulling enable	P2REN	07h
Port P2 selection 0	P2SEL0	0Bh
Port P2 selection 1	P2SEL1	0Ch
Port P2 interrupt vector word	P2IV	1Eh
Port P2 interrupt edge select	P2IES	19h
Port P2 interrupt enable	P2IE	1Bh
Port P2 interrupt flag	P2IFG	1Dh

Table 6-33. Port P3 Registers (Base Address: 0220h)

REGISTER DESCRIPTION	ACRONYM	OFFSET
Port P3 input	P3IN	00h
Port P3 output	P3OUT	02h
Port P3 direction	P3DIR	04h
Port P3 pulling enable	P3REN	06h
Port P3 selection 0	P3SEL0	0Ah
Port P3 selection 1	P3SEL1	0

Table 6-34. RTC Registers (Base Address: 0300h)

REGISTER DESCRIPTION	ACRONYM	OFFSET
RTC control	RTCCTL	00h
RTC interrupt vector	RTCIV	04h
RTC modulo	RTCMOD	08h
RTC counter	RTCCNT	0Ch

Table 6-35. Timer0_A3 Registers (Base Address: 0380h)

REGISTER DESCRIPTION	ACRONYM	OFFSET
TA0 control	TA0CTL	00h
Capture/compare control 0	TA0CCTL0	02h
Capture/compare control 1	TA0CCTL1	04h
Capture/compare control 2	TA0CCTL2	06h
TA0 counter	TA0R	10h
Capture/compare 0	TA0CCR0	12h
Capture/compare 1	TA0CCR1	14h
Capture/compare 2	TA0CCR2	16h
TA0 expansion 0	TA0EX0	20h
TA0 interrupt vector	TA0IV	2Eh

Table 6-36. Timer1_A3 Registers (Base Address: 03C0h)

REGISTER DESCRIPTION	ACRONYM	OFFSET
TA1 control	TA1CTL	00h
Capture/compare control 0	TA1CCTL0	02h
Capture/compare control 1	TA1CCTL1	04h
Capture/compare control 2	TA1CCTL2	06h
TA1 counter	TA1R	10h
Capture/compare 0	TA1CCR0	12h
Capture/compare 1	TA1CCR1	14h
Capture/compare 2	TA1CCR2	16h
TA1 expansion 0	TA1EX0	20h
TA1 interrupt vector	TA1IV	2Eh

Table 6-37. Timer2_A2 Registers (Base Address: 0400h)

REGISTER DESCRIPTION	ACRONYM	OFFSET
TA2 control	TA2CTL	00h
Capture/compare control 0	TA2CCTL0	02h
Capture/compare control 1	TA2CCTL1	04h
TA2 counter	TA2R	10h
Capture/compare 0	TA2CCR0	12h
Capture/compare 1	TA2CCR1	14h
TA2 expansion 0	TA2EX0	20h
TA2 interrupt vector	TA2IV	2Eh

Table 6-38. Timer3_A2 Registers (Base Address: 0440h)

REGISTER DESCRIPTION	ACRONYM	OFFSET
TA3 control	TA3CTL	00h
Capture/compare control 0	TA3CCTL0	02h
Capture/compare control 1	TA3CCTL1	04h
TA3 counter	TA3R	10h
Capture/compare 0	TA3CCR0	12h
Capture/compare 1	TA3CCR1	14h
TA3 expansion 0	TA3EX0	20h
TA3 interrupt vector	TA3IV	2Eh

Table 6-39. MPY32 Registers (Base Address: 04C0h)

REGISTER DESCRIPTION	ACRONYM	OFFSET
16-bit operand 1 – multiply	MPY	00h
16-bit operand 1 – signed multiply	MPYS	02h
16-bit operand 1 – multiply accumulate	MAC	04h
16-bit operand 1 – signed multiply accumulate	MACS	06h
16-bit operand 2	OP2	08h
16 × 16 result low word	RESLO	0Ah
16 × 16 result high word	RESHI	0Ch
16 × 16 sum extension	SUMEXT	0Eh
32-bit operand 1 – multiply low word	MPY32L	10h
32-bit operand 1 – multiply high word	MPY32H	12h
32-bit operand 1 – signed multiply low word	MPYS32L	14h
32-bit operand 1 – signed multiply high word	MPYS32H	16h
32-bit operand 1 – multiply accumulate low word	MAC32L	18h
32-bit operand 1 – multiply accumulate high word	MAC32H	1Ah
32-bit operand 1 – signed multiply accumulate low word	MACS32L	1Ch
32-bit operand 1 – signed multiply accumulate high word	MACS32H	1Eh
32-bit operand 2 – low word	OP2L	20h
32-bit operand 2 – high word	OP2H	22h
32 × 32 result 0 – least significant word	RES0	24h
32 × 32 result 1	RES1	26h
32 × 32 result 2	RES2	28h
32 × 32 result 3 – most significant word	RES3	2Ah
MPY32 control 0	MPY32CTL0	2Ch

Table 6-40. eUSCI_A0 Registers (Base Address: 0500h)

REGISTER DESCRIPTION	ACRONYM	OFFSET
eUSCI_A control word 0	UCA0CTLW0	00h
eUSCI_A control word 1	UCA0CTLW1	02h
eUSCI_A control rate 0	UCA0BR0	06h
eUSCI_A control rate 1	UCA0BR1	07h
eUSCI_A modulation control	UCA0MCTLW	08h
eUSCI_A status	UCA0STAT	0Ah
eUSCI_A receive buffer	UCA0RXBUF	0Ch
eUSCI_A transmit buffer	UCA0TXBUF	0Eh
eUSCI_A LIN control	UCA0ABCTL	10h
eUSCI_A IrDA transmit control	IUCA0IRTCTL	12h
eUSCI_A IrDA receive control	IUCA0IRRCTL	13h
eUSCI_A interrupt enable	UCA0IE	1Ah
eUSCI_A interrupt flags	UCA0IFG	1Ch
eUSCI_A interrupt vector word	UCA0IV	1Eh

Table 6-41. eUSCI_A1 Registers (Base Address: 0520h)

REGISTER DESCRIPTION	ACRONYM	OFFSET
eUSCI_A control word 0	UCA1CTLW0	00h
eUSCI_A control word 1	UCA1CTLW1	02h
eUSCI_A control rate 0	UCA1BR0	06h
eUSCI_A control rate 1	UCA1BR1	07h
eUSCI_A modulation control	UCA1MCTLW	08h
eUSCI_A status	UCA1STAT	0Ah
eUSCI_A receive buffer	UCA1RXBUF	0Ch
eUSCI_A transmit buffer	UCA1TXBUF	0Eh
eUSCI_A LIN control	UCA1ABCTL	10h
eUSCI_A IrDA transmit control	IUCA1IRTCTL	12h
eUSCI_A IrDA receive control	IUCA1IRRCTL	13h
eUSCI_A interrupt enable	UCA1IE	1Ah
eUSCI_A interrupt flags	UCA1IFG	1Ch
eUSCI_A interrupt vector word	UCA1IV	1Eh

Table 6-42. eUSCI_B0 Registers (Base Address: 0540h)

REGISTER DESCRIPTION	ACRONYM	OFFSET
eUSCI_B control word 0	UCB0CTLW0	00h
eUSCI_B control word 1	UCB0CTLW1	02h
eUSCI_B bit rate 0	UCB0BR0	06h
eUSCI_B bit rate 1	UCB0BR1	07h
eUSCI_B status word	UCB0STATW	08h
eUSCI_B byte counter threshold	UCB0TBCNT	0Ah
eUSCI_B receive buffer	UCB0RXBUF	0Ch
eUSCI_B transmit buffer	UCB0TXBUF	0Eh
eUSCI_B I2C own address 0	UCB0I2COA0	14h
eUSCI_B I2C own address 1	UCB0I2COA1	16h
eUSCI_B I2C own address 2	UCB0I2COA2	18h
eUSCI_B I2C own address 3	UCB0I2COA3	1Ah
eUSCI_B receive address	UCB0ADDRX	1Ch
eUSCI_B address mask	UCB0ADDMASK	1Eh
eUSCI_B I2C slave address	UCB0I2CSA	20h
eUSCI_B interrupt enable	UCB0IE	2Ah
eUSCI_B interrupt flags	UCB0IFG	2Ch
eUSCI_B interrupt vector word	UCB0IV	2Eh

Table 6-43. Backup Memory Registers (Base Address: 0660h)

REGISTER DESCRIPTION	ACRONYM	OFFSET
Backup memory 0	BAKMEM0	00h
Backup memory 1	BAKMEM1	02h
Backup memory 2	BAKMEM2	04h
Backup memory 3	BAKMEM3	06h
Backup memory 4	BAKMEM4	08h
Backup memory 5	BAKMEM5	0Ah
Backup memory 6	BAKMEM6	0Ch
Backup memory 7	BAKMEM7	0Eh
Backup memory 8	BAKMEM8	10h
Backup memory 9	BAKMEM9	12h
Backup memory 10	BAKMEM10	14h
Backup memory 11	BAKMEM11	16h
Backup memory 12	BAKMEM12	18h
Backup memory 13	BAKMEM13	1Ah
Backup memory 14	BAKMEM14	1Ch
Backup memory 15	BAKMEM15	1Eh

Table 6-44. ADC Registers (Base Address: 0700h)

REGISTER DESCRIPTION	ACRONYM	OFFSET
ADC control 0	ADCCTL0	00h
ADC control 1	ADCCTL1	02h
ADC control 2	ADCCTL2	04h
ADC window comparator low threshold	ADCLO	06h
ADC window comparator high threshold	ADCHI	08h
ADC memory control 0	ADCMCTL0	0Ah
ADC conversion memory	ADCMEM0	12h
ADC interrupt enable	ADCIE	1Ah
ADC interrupt flags	ADCIFG	1Ch
ADC interrupt vector word	ADCIV	1Eh

6.14 Identification

6.14.1 Revision Identification

The device revision information is included as part of the top-side marking on the device package. The device-specific errata sheet describes these markings (see [Section 8.2](#)).

The hardware revision is also stored in the Device Descriptor structure in the Info Block section. For details on this value, see the Hardware Revision entries in [Section 6.12](#).

6.14.2 Device Identification

The device type can be identified from the top-side marking on the device package. The device-specific errata sheet describes these markings (see [Section 8.2](#)).

A device identification value is also stored in the Device Descriptor structure in the Info Block section. For details on this value, see the Device ID entries in [Section 6.12](#).

6.14.3 JTAG Identification

Programming through the JTAG interface, including reading and identifying the JTAG ID, is described in detail in the *MSP430 Programming Via the JTAG Interface User's Guide* ([SLAU320](#)).

7 Applications, Implementation, and Layout

NOTE

Information in the following Applications section is not part of the TI component specification, and TI does not warrant its accuracy or completeness. TI's customers are responsible for determining suitability of components for their purposes. Customers should validate and test their design implementation to confirm system functionality.

7.1 Device Connection and Layout Fundamentals

This section discusses the recommended guidelines when designing with the MSP430 devices. These guidelines are to make sure that the device has proper connections for powering, programming, debugging, and optimum analog performance.

7.1.1 Power Supply Decoupling and Bulk Capacitors

TI recommends connecting a combination of a 10- μ F plus a 100-nF low-ESR ceramic decoupling capacitor to the DVCC and DVSS pins. Higher-value capacitors may be used but can impact supply rail ramp-up time. Decoupling capacitors must be placed as close as possible to the pins that they decouple (within a few millimeters). Additionally, TI recommends separated grounds with a single-point connection for better noise isolation from digital-to-analog circuits on the board and to achieve high analog accuracy.

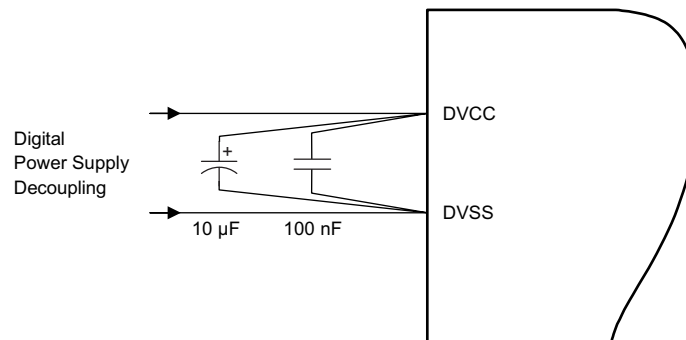

Figure 7-1. Power Supply Decoupling

7.1.2 External Oscillator

This device supports only a low-frequency crystal (32 kHz) on the XIN and XOUT pins. External bypass capacitors for the crystal oscillator pins are required.

It is also possible to apply digital clock signals to the XIN input pin that meet the specifications of the respective oscillator if the appropriate XT1BYPASS mode is selected. In this case, the associated XOUT pin can be used for other purposes. If the XIN and XOUT pins are not used, they must be terminated according to [Section 4.6](#).

Figure 7-2 shows a typical connection diagram.

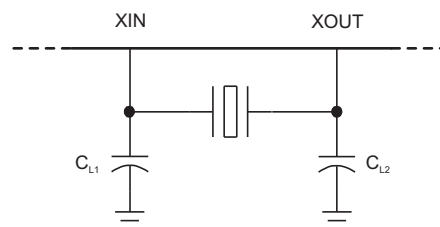

Figure 7-2. Typical Crystal Connection

See the application report *MSP430 32-kHz Crystal Oscillators (SLAA322)* for more information on selecting, testing, and designing a crystal oscillator with the MSP430 devices.

7.1.3 JTAG

With the proper connections, the debugger and a hardware JTAG interface (such as the MSP-FET or MSP-FET430UIF) can be used to program and debug code on the target board. In addition, the connections also support the MSP-GANG production programmers, thus providing an easy way to program prototype boards, if desired. Figure 7-3 shows the connections between the 14-pin JTAG connector and the target device required to support in-system programming and debugging for 4-wire JTAG communication. Figure 7-4 shows the connections for 2-wire JTAG mode (Spy-Bi-Wire).

The connections for the MSP-FET and MSP-FET430UIF interface modules and the MSP-GANG are identical. Both can supply V_{CC} to the target board (through pin 2). In addition, the MSP-FET and MSP-FET430UIF interface modules and MSP-GANG have a V_{CC} sense feature that, if used, requires an alternate connection (pin 4 instead of pin 2). The V_{CC} sense feature detects the local V_{CC} present on the target board (that is, a battery or other local power supply) and adjusts the output signals accordingly. Figure 7-3 and Figure 7-4 show a jumper block that supports both scenarios of supplying V_{CC} to the target board. If this flexibility is not required, the desired V_{CC} connections may be hard-wired to eliminate the jumper block. Pins 2 and 4 must not be connected at the same time.

For additional design information regarding the JTAG interface, see the *MSP430 Hardware Tools User's Guide (SLAU278)*.

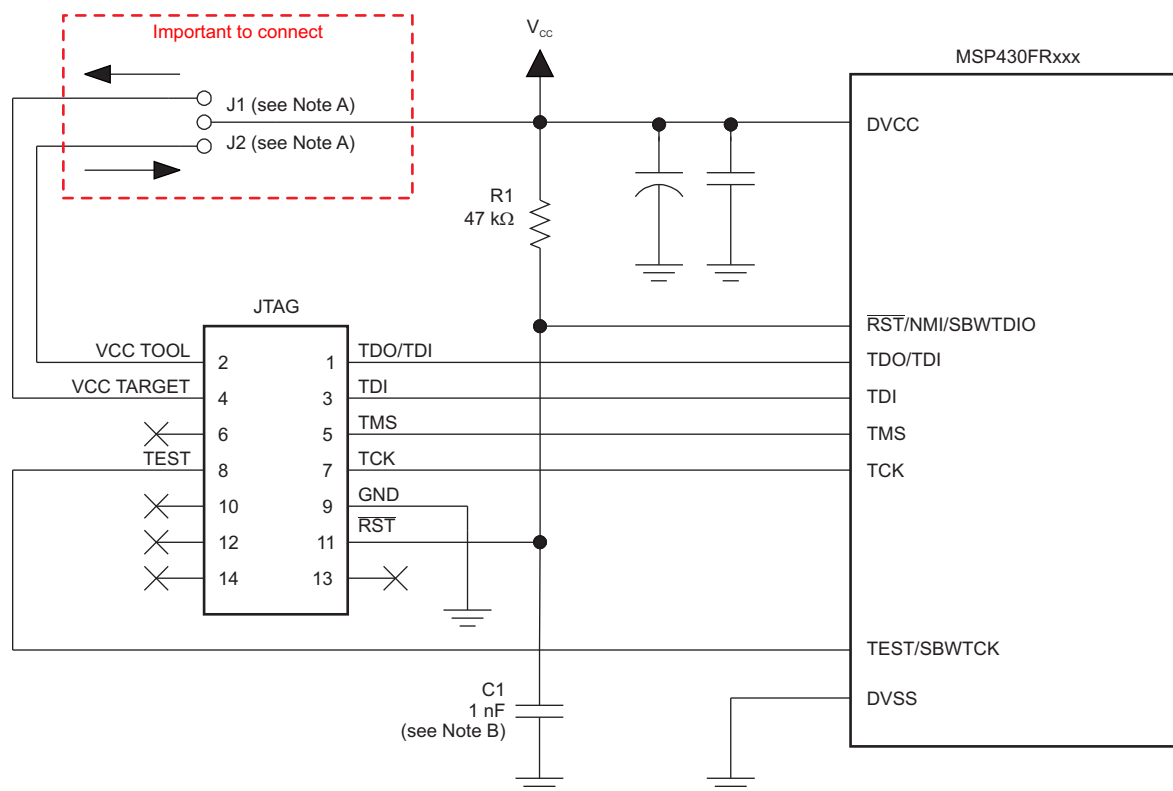

Copyright © 2016, Texas Instruments Incorporated

- If a local target power supply is used, make connection J1. If power from the debug or programming adapter is used, make connection J2.
- The upper limit for C1 is 1.1 nF when using current TI tools.

Figure 7-3. Signal Connections for 4-Wire JTAG Communication

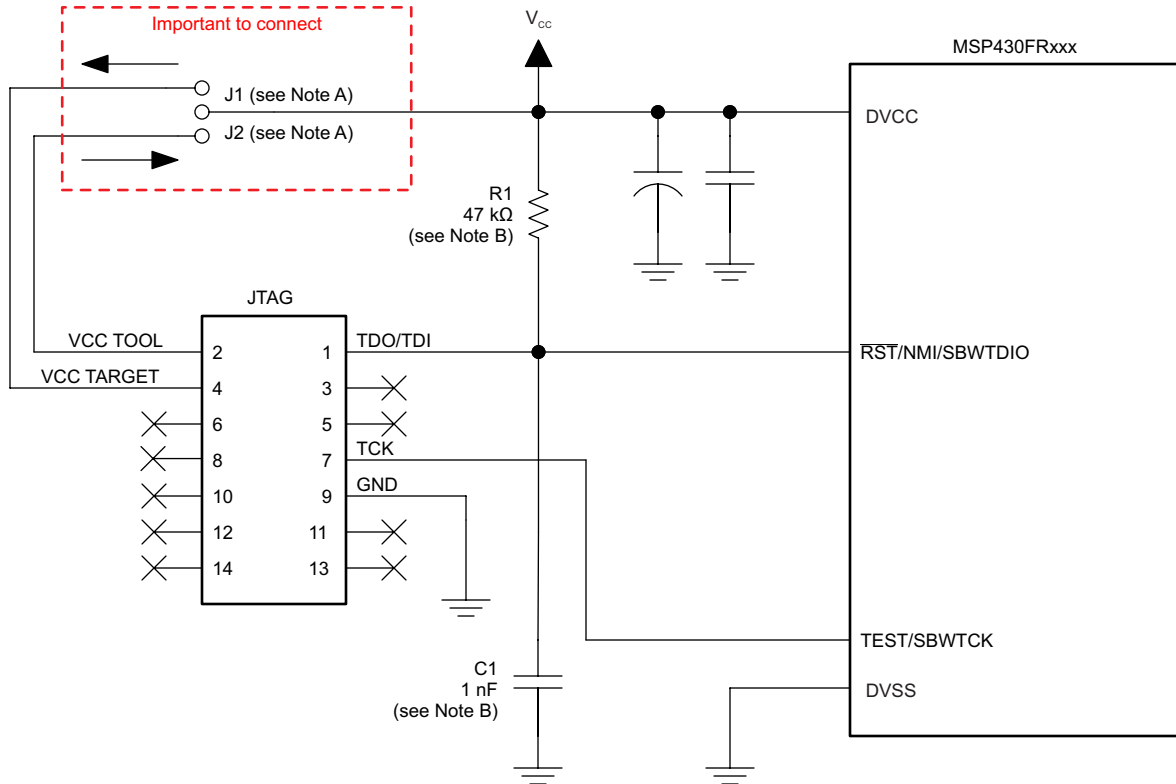

Copyright © 2016, Texas Instruments Incorporated

- Make connection J1 if a local target power supply is used, or make connection J2 if the target is powered from the debug or programming adapter.
- The device $\overline{\text{RST/NMI/SBWTIO}}$ pin is used in 2-wire mode for bidirectional communication with the device during JTAG access, and any capacitance that is attached to this signal may affect the ability to establish a connection with the device. The upper limit for C1 is 1.1 nF when using current TI tools.

Figure 7-4. Signal Connections for 2-Wire JTAG Communication (Spy-Bi-Wire)

7.1.4 Reset

The reset pin can be configured as a reset function (default) or as an NMI function in the Special Function Register (SFR), SFRRPCR.

In reset mode, the $\overline{\text{RST/NMI}}$ pin is active low, and a pulse applied to this pin that meets the reset timing specifications generates a BOR-type device reset.

Setting SYSNMI causes the $\overline{\text{RST/NMI}}$ pin to be configured as an external NMI source. The external NMI is edge sensitive, and its edge is selectable by SYSNMIIES. Setting the NMIIE enables the interrupt of the external NMI. When an external NMI event occurs, the NMIIFG is set.

The $\overline{\text{RST/NMI}}$ pin can have either a pullup or pulldown that is enabled or not. SYSRSTUP selects either pullup or pulldown, and SYSRSTRE causes the pullup (default) or pulldown to be enabled (default) or not. If the $\overline{\text{RST/NMI}}$ pin is unused, it is required either to select and enable the internal pullup or to connect an external 47-k Ω pullup resistor to the $\overline{\text{RST/NMI}}$ pin with a 1.1-nF pulldown capacitor. The pulldown capacitor should not exceed 1.1 nF when using devices with Spy-Bi-Wire interface in Spy-Bi-Wire mode or in 4-wire JTAG mode with TI tools like FET interfaces or GANG programmers.

See the *MSP430FR4xx and MSP430FR2xx Family User's Guide (SLAU445)* for more information on the referenced control registers and bits.

7.1.5 Unused Pins

For details on the connection of unused pins, see [Section 4.6](#).

7.1.6 General Layout Recommendations

- Proper grounding and short traces for external crystal to reduce parasitic capacitance. See the application report *MSP430 32-kHz Crystal Oscillators* (SLAA322) for recommended layout guidelines.
- Proper bypass capacitors on DVCC and reference pins, if used.
- Avoid routing any high-frequency signal close to an analog signal line. For example, keep digital switching signals such as PWM or JTAG signals away from the oscillator circuit and ADC signals.
- Refer to the *Circuit Board Layout Techniques* design guide (SLOA089) for a detailed discussion of PCB layout considerations. This document is written primarily about op amps, but the guidelines are generally applicable for all mixed-signal applications.
- Proper ESD level protection should be considered to protect the device from unintended high-voltage electrostatic discharge. See the application report *MSP430 System-Level ESD Considerations* (SLAA530) for guidelines.

7.1.7 Do's and Don'ts

During power up, power down, and device operation, DVCC must not exceed the limits specified in [Section 5.1, Absolute Maximum Ratings](#). Exceeding the specified limits may cause malfunction of the device including erroneous writes to RAM and FRAM.

7.2 Peripheral- and Interface-Specific Design Information

7.2.1 ADC Peripheral

7.2.1.1 Partial Schematic

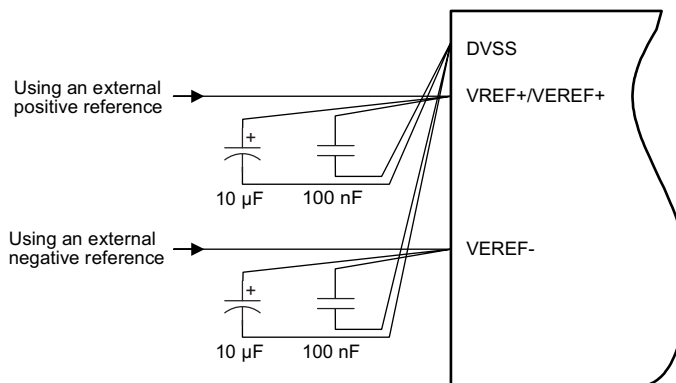

Figure 7-5. ADC Grounding and Noise Considerations

7.2.1.2 Design Requirements

As with any high-resolution ADC, appropriate printed-circuit board layout and grounding techniques should be followed to eliminate ground loops, unwanted parasitic effects, and noise.

Ground loops are formed when return current from the ADC flows through paths that are common with other analog or digital circuitry. If care is not taken, this current can generate small unwanted offset voltages that can add to or subtract from the reference or input voltages of the ADC. The general guidelines in [Section 7.1.1](#) combined with the connections shown in [Figure 7-5](#) prevent this.

In addition to grounding, ripple and noise spikes on the power-supply lines that are caused by digital switching or switching power supplies can corrupt the conversion result. TI recommends a noise-free design using separate analog and digital ground planes with a single-point connection to achieve high accuracy.

Figure 7-5 shows the recommended decoupling circuit when an external voltage reference is used. The internal reference module has a maximum drive current as described in the sections *ADC Pin Enable* and *1.2-V Reference Settings* of the *MSP430FR4xx and MSP430FR2xx Family User's Guide (SLAU445)*.

The reference voltage must be a stable voltage for accurate measurements. The capacitor values that are selected in the general guidelines filter out the high- and low-frequency ripple before the reference voltage enters the device. In this case, the 10- μ F capacitor buffers the reference pin and filters any low-frequency ripple. A bypass capacitor of 100 nF filters out any high-frequency noise.

7.2.1.3 Layout Guidelines

Components that are shown in the partial schematic (see Figure 7-5) should be placed as close as possible to the respective device pins to avoid long traces, because they add additional parasitic capacitance, inductance, and resistance on the signal.

Avoid routing analog input signals close to a high-frequency pin (for example, a high-frequency PWM), because the high-frequency switching can be coupled into the analog signal.

7.2.2 CapTivate Peripheral

This section provides a brief introduction to the CapTivate technology with examples of PCB layout and performance from the design kit. A more detailed description of the CapTivate technology and the tools needed to be successful, application development tools, hardware design guides, and software library, can be found in the [CapTivate Technology Design Center](#).

7.2.2.1 Device Connection and Layout Fundamentals

7.2.2.1.1 VREG

The VREG pin requires a 1- μ F capacitor to regulate the 1.5-V LDO internal to the device (Vreg). This capacitor must be placed as close as possible to the microcontroller. Figure 7-6 shows the layout of the CAPTIVATE-FR2633, zooming in on the capacitor connected to the VREG pin.

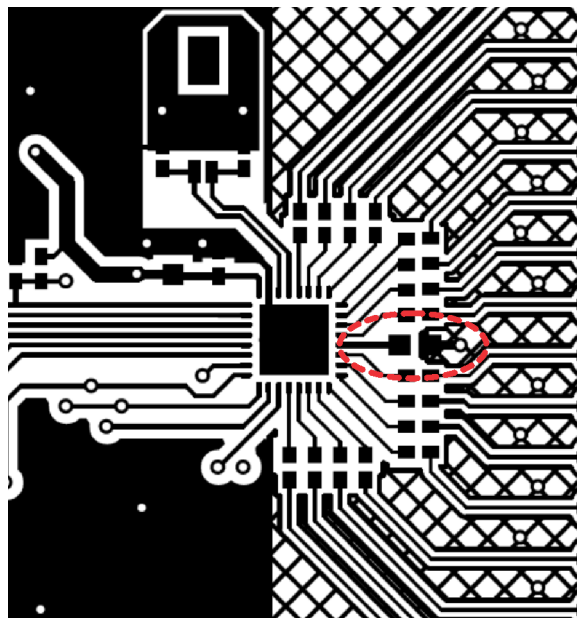

Figure 7-6. VREG Capacitor and Channel Series Resistors

7.2.2.1.2 ESD Protection

Typically, the laminate overlay provides several kilovolts of breakdown isolation to protect the circuit from ESD strikes. More ESD protection can be added with a series resistor placed on each channel used. A value of $470\ \Omega$ is recommended and is found on the development tool.

7.2.2.1.3 Mutual- and Self-Capacitance

CapTIvate technology enables both self-mode and mutual-mode capacitance measurements. [Section 7.2.2.1.4](#) and [Section 7.2.2.1.5](#) provide a brief description and examples, taken from the CAPTIVATE-PHONE and CAPTIVATE-BSWP panels found in the design kit, for self- and mutual-mode capacitance measurements, respectively.

7.2.2.1.4 Self-Capacitance

Self-capacitance electrodes are characterized by having only one channel from the IC that both excites and measures the capacitance. The capacitance being measured is between the electrode and earth ground, so any capacitance local to the PCB or outside of the PCB (a touch event) influences the measurement.

PCB layout design guidelines to minimize local parasitic capacitances and maximize the affect of external capacitances (a touch) can be found in the [CapTIvate Technology Design Center](#). [Figure 7-7](#), taken from the CAPTIVATE-BSWP panel, shows that the area of the button should be consistent with the touch area, in this case a 400-mil (10.16-mm) diameter circle. To minimize parasitics on the PCB, the ground pour on the bottom layer is hatched and there is no pour directly below the electrode: 50-mil (1.27-mm) spacing between the electrode and ground fill.

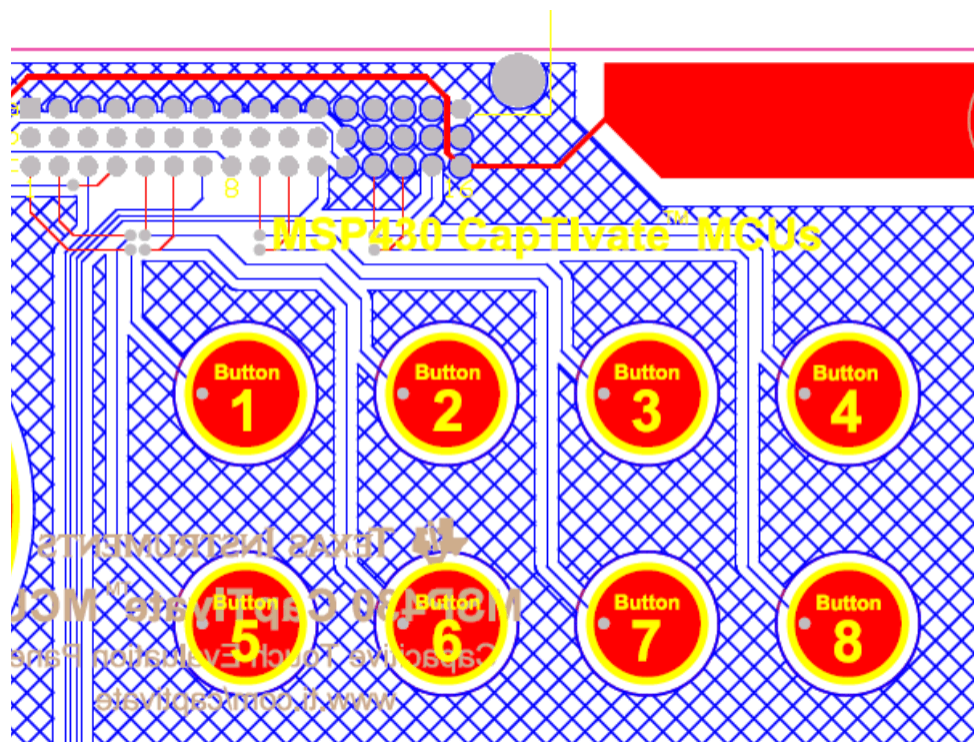

Figure 7-7. Self-Capacitance Electrodes

7.2.2.1.5 Mutual Capacitance

Mutual capacitance is characterized by having two channels, receive (Rx) and transmit (Tx), from the IC with the focus being the capacitance between the two. Coupling to earth ground still has an affect, but this is secondary to the mutual capacitance between the Rx and Tx electrodes.

PCB layout design guidelines for mutual capacitance structures can also be found in the [CapTivate Technology Design Center](#). Figure 7-8, taken from CAPTIVATE-PHONE, shows that the Tx electrode is a copy of the Rx electrode expanded to surround the Rx electrode. Both the Rx and Tx electrodes are in the shape of hollow squares: the Tx electrode is 300 x 300 mils (7.62 x 7.62 mm) and the Rx electrode is 150 x 150 mils (3.81 x 3.81 mm). Both electrodes are 50 mils (1.27 mm) wide.

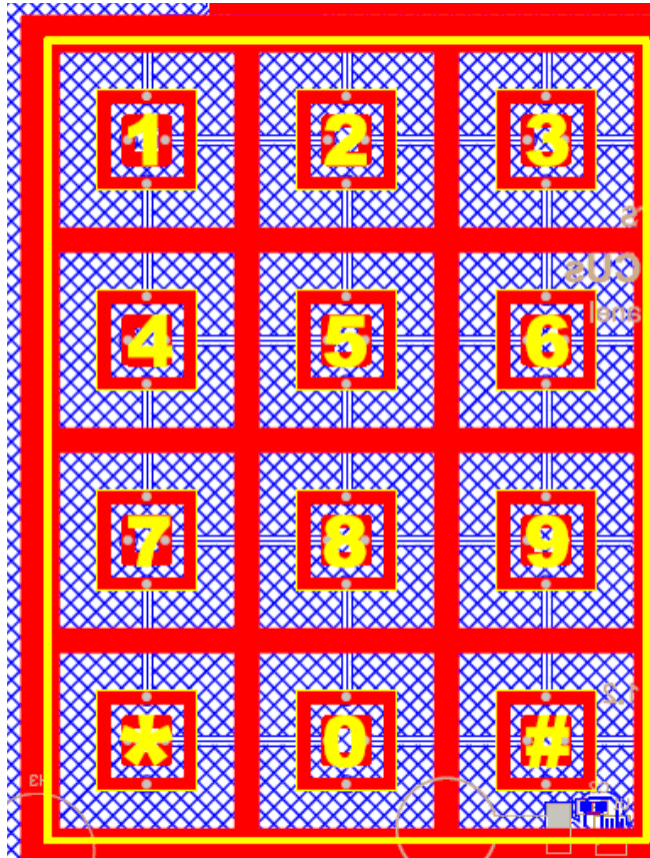

Figure 7-8. Mutual-Capacitance Electrodes

7.2.2.2 Measurements

The following measurements are taken from the [CapTivate Technology Design Center](#), using the CAPTIVATE-PHONE and CAPTIVATE-BSWP panels. Unless otherwise stated, the settings used are the out-of-box settings, which can be found in the example projects. The intent of these measurements is to show performance in a configuration that is readily available and reproducible.



Figure 7-9. CAPTIVATE-PHONE and CAPTIVATE-BSWP Panels

7.2.2.2.1 SNR

The [CapTivate technology Design Center](#) provides a specific view for analyzing the signal-to-noise ratio of each element. [Figure 7-10](#) shows that the SNR tab can be used to establish a confidence level in the settings that are chosen.

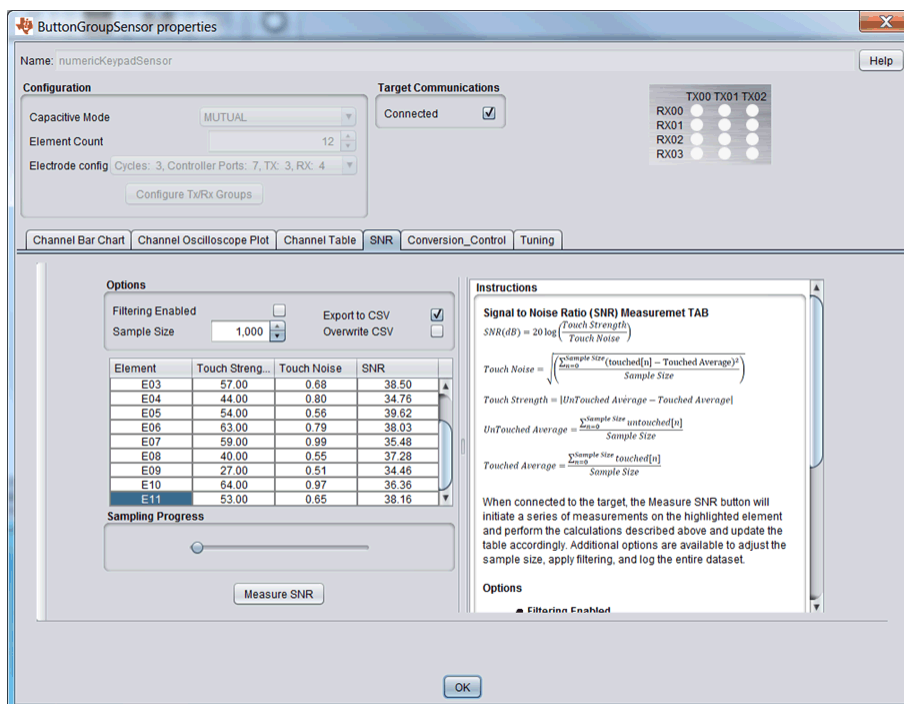

Figure 7-10. SNR Tab

[Table 7-1](#) summarizes the SNR results from the CAPTIVATE-PHONE panel keypad, numericKeypadSensor.

Table 7-1. CAPTIVATE-PHONE SNR Results

ELEMENT	SNR (dB)	ELEMENT	SNR (dB)
E00	31.49	E06	38.03
E01	37.20	E07	35.48
E02	36.34	E08	37.28
E03	38.50	E09	–
E04	34.76	E10	–
E05	39.62	E11	–

Table 7-2 summarizes the SNR results from the CAPTIVATE-BSWP panel keypad, keypadSensor.

Table 7-2. CAPTIVATE-BSWP SNR Results

ELEMENT	SNR (dB)	ELEMENT	SNR (dB)
E00	37.90	E04	39.28
E01	47.26	E05	29.67
E02	36.79	E06	36.63
E03	33.73	E07	34.07

7.2.2.2 Sensitivity

To show sensitivity, in terms of farads, the internal reference capacitor is used as the change in capacitance. In the mutual-capacitance case, the 0.1-pF capacitor is used. In the self-capacitance case, the 1-pF reference capacitor is used. For simplicity, the results for only button 1 on both the CAPTIVATE-PHONE and CAPTIVATE-BSWP panels are reported in Table 7-3.

Table 7-3. Button Sensitivity

CONVERSION COUNT	CONVERSION GAIN	CAPTIVATE-PHONE BUTTON 1		CAPTIVATE-BSWP BUTTON 1	
		CONVERSION TIME (μs)	COUNTS FOR 0.1-pF CHANGE	CONVERSION TIME (μs)	COUNTS FOR 1-pF CHANGE
100	100	25	6	50	8
200	200	50	10	100	16
200	100	50	21	100	31
800	400	200	70	400	112
800	200	200	140	400	202
800	100	200	257	400	333

An alternative measure in sensitivity is the ability to resolve capacitance change over a wide range of base capacitance. Table 7-4 shows example conversion times (for a self-mode measurement of discrete capacitors) that can be used to achieve the desired resolution for a given parasitic load capacitance.

Table 7-4. Button Sensitivity

CAPACITANCE C_p (pF) ⁽¹⁾	CONVERSION COUNT/GAIN	CONVERSION TIME (μ s)	COUNTS FOR 0.130-pF CHANGE	COUNTS FOR 0.260-pF CHANGE	COUNTS FOR 0.520-pF CHANGE
23	400/100	200	10	23	35
50	550/100	275	11	24	37
78	650/100	325	11	23	36
150	850/100	425	11	22	35
150 ⁽²⁾	1200/200	600	11	23	37
200 ⁽²⁾	1200/150	600	13	26	41

(1) These measurements were taken with the CapTIvate MCU processor board with the 470- Ω series resistors replaced with 0- Ω resistors.

(2) 0-V discharge voltage is used.

7.2.2.2.3 Power

The low-power mode LPM3 specifications in [Section 5.7](#) are derived from the CapTIvate technology design kit as indicated in the notes.

7.3 Typical Applications

[Table 7-5](#) lists tools that demonstrate the use of the MSP430FR263x devices in various real-world application scenarios. Consult these designs for additional guidance regarding schematics, layout, and software implementation. For the most up-to-date list of available TI Designs, see the device-specific product folders listed in [Section 8.3](#).

Table 7-5. TI Designs

DESIGN NAME	LINK
MSP CapTIvate™ MCU Development Kit Evaluation Model	http://www.ti.com/tool/msp-capt-fr2633
Capacitive Touch Thermostat User Interface Reference Design	http://www.ti.com/tool/tidm-captivate-thermostat-ui

8 Device and Documentation Support

8.1 Device Support

8.1.1 Development Support

8.1.1.1 Getting Started and Next Steps

For more information on the MSP low-power microcontrollers and the tools and libraries that are available to help with your development, visit the [Getting Started](#) page.

8.1.1.2 Development Tools Support

8.1.1.2.1 Hardware Features

See the *Code Composer Studio for MSP430 User's Guide* ([SLAU157](#)) for details on the available features.

MSP430 ARCHITECTURE	4-WIRE JTAG	2-WIRE JTAG	BREAK-POINTS (N)	RANGE BREAK-POINTS	CLOCK CONTROL	STATE SEQUENCER	TRACE BUFFER	LPMx.5 DEBUGGING SUPPORT	EEM VERSION
MSP430Xv2	Yes	Yes	3	Yes	Yes	No	No	No	S

8.1.1.2.2 Recommended Hardware Options

All MSP430 MCUs are supported by a wide variety of software and hardware development tools. Tools are available from TI and various third parties. See them all at [MSP430 Tools](#).

8.1.1.2.2.1 Experimenter Boards

Experimenter Boards and Evaluation kits are available for some MSP430 devices. These kits feature additional hardware components and connectivity for full system evaluation and prototyping. See [MSP430 Tools](#) for details.

8.1.1.2.2.2 Debugging and Programming Tools

Hardware programming and debugging tools are available from TI and from its third-party suppliers. See the full list of available tools at [MSP430 Tools](#).

PART NUMBER	PC PORT	FEATURES	PROVIDER
MSP-FET430UIF	USB	MSP430 USB debugging interface. Compatible with 4-wire JTAG and 2-wire Spy-Bi-Wire (SBW) JTAG modes	Texas Instruments
MSP-FET	USB	MSP MCU programmer and debugger. The MSP-FET is compatible with Code Composer Studio v6 and later.	Texas Instruments

8.1.1.2.2.3 Production Programmers

The production programmers expedite loading firmware to devices by programming several devices simultaneously.

PART NUMBER	PC PORT	FEATURES	PROVIDER
MSP-GANG	Serial and USB	Program up to eight devices at a time. Works with a PC or as a stand-alone package.	Texas Instruments

8.1.1.2.3 Recommended Software Options

8.1.1.2.3.1 Integrated Development Environments

Software development tools are available from TI or from third parties. Open-source solutions are also available.

This device is supported by Code Composer Studio™ IDE (CCS).

8.1.1.2.3.2 MSPWare

MSPWare is a collection of code examples, data sheets, and other design resources for all MSP devices delivered in a convenient package. In addition to providing a complete collection of existing MSP design resources, MSPWare also includes a high-level API called MSP430 Driver Library. This library makes it easy to program MSP hardware. MSPWare is available as a component of CCS or as a stand-alone package.

8.1.1.2.3.3 Command-Line Programmer

MSP Flasher is an open-source shell-based interface for programming MSP MCUs through a FET programmer or eZ430 using JTAG or Spy-Bi-Wire (SBW) communication. MSP Flasher can be used to download binary files (.txt or .hex) files directly to the MSP MCU without the need for an IDE.

8.1.2 Device Nomenclature

To designate the stages in the product development cycle, TI assigns prefixes to the part numbers of all MSP430 MCUs and support tools. Each MSP430 MCU commercial family member has one of three prefixes: MSP, PMS, or XMS (for example, MSP430FR2633). TI recommends two of three possible prefix designators for its support tools: MSP and MSPX. These prefixes represent evolutionary stages of product development from engineering prototypes (with XMS for devices and MSPX for tools) through fully qualified production devices and tools (with MSP for devices and MSP for tools).

Device development evolutionary flow:

XMS – Experimental device that is not necessarily representative of the electrical specifications of the final device

MSP – Fully qualified production device

Support tool development evolutionary flow:

MSPX – Development-support product that has not yet completed TI internal qualification testing.

MSP – Fully-qualified development-support product

XMS devices and MSPX development-support tools are shipped against the following disclaimer:

"Developmental product is intended for internal evaluation purposes."

MSP devices and MSP development-support tools have been characterized fully, and the quality and reliability of the device have been demonstrated fully. TI's standard warranty applies.

Predictions show that prototype devices (XMS) have a greater failure rate than the standard production devices. TI recommends that these devices not be used in any production system because their expected end-use failure rate still is undefined. Only qualified production devices are to be used.

TI device nomenclature also includes a suffix with the device family name. This suffix indicates the package type (for example, RHB) and temperature range (for example, T). [Figure 8-1](#) provides a legend for reading the complete device name for any family member.

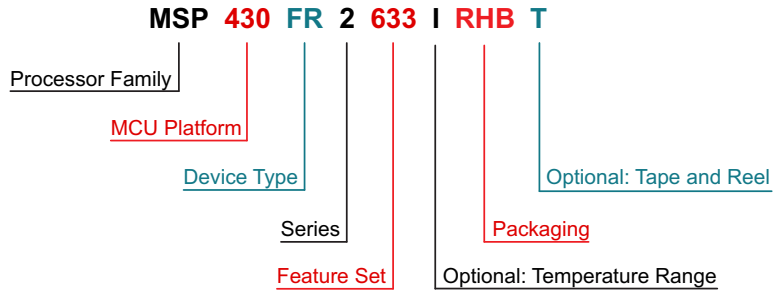

Processor Family	MSP = Mixed-signal processor XMS = Experimental silicon
MCU Platform	430 = MSP430 16-bit low-power platform
Device Type	Memory Type FR = FRAM
Series	4 = Up to 16 MHz with LCD 2 = Up to 16 MHz without LCD
Feature Set	CapTIvate Performance 633 = 4 CapTIvate blocks support up to 16 self- or 64 mutual-capacitance buttons 533 = 4 CapTIvate blocks support up to 16 self- or 16 mutual-capacitance buttons 632 = 4 CapTIvate blocks support up to 8 self- or 16 mutual-capacitance buttons 532 = 4 CapTIvate blocks support up to 8 self- or 8 mutual-capacitance buttons
Optional: Temperature Range	S = 0°C to 50°C I = -40°C to 85°C T = -40°C to 105°C
Packaging	www.ti.com/packaging
Optional: Distribution Format	T = Small Reel R = Large Reel No Marking = Tube or Tray

Figure 8-1. Device Nomenclature

8.2 Documentation Support

The following documents describe the MSP430FR263x and MSP430FR253x MCUs. Copies of these documents are available on the Internet at www.ti.com.

- SLAU445** *MSP430FR4xx and MSP430FR2xx Family User's Guide.* Detailed description of all modules and peripherals available in this device family.
- SLAZ660** *MSP430FR2633 Device Erratasheet.* Describes the known exceptions to the functional specifications for all silicon revisions of this MCU.
- SLAZ661** *MSP430FR2533 Device Erratasheet.* Describes the known exceptions to the functional specifications for all silicon revisions of this MCU.
- SLAZ662** *MSP430FR2632 Device Erratasheet.* Describes the known exceptions to the functional specifications for all silicon revisions of this MCU.
- SLAZ663** *MSP430FR2532 Device Erratasheet.* Describes the known exceptions to the functional specifications for all silicon revisions of this MCU.
- SLAU278** *MSP430 Hardware Tools User's Guide.* This manual describes the hardware of the TI MSP-FET430 Flash Emulation Tool (FET). The FET is the program development tool for the MSP430 ultra-low-power microcontroller. Both available interface types, the parallel port interface and the USB interface, are described.
- SLAU610** *MSP430FR4xx and MSP430FR2xx Bootloader (BSL) User's Guide.* The bootloader (BSL) provides a method to program memory during MSP430 MCU project development and updates. It can be activated by a utility that sends commands using a serial protocol. The BSL enables the user to control the activity of the MSP430 MCU and to exchange data using a personal computer or other device.
- SLAU320** *MSP430 Programming Via the JTAG Interface.* This document describes the functions that are required to erase, program, and verify the memory module of the MSP430 flash-based and FRAM-based microcontroller families using the JTAG communication port. In addition, it describes how to program the JTAG access security fuse that is available on all MSP430 MCUs. This document describes access to the MCU using both the standard 4-wire JTAG interface and the 2-wire JTAG interface, which is also referred to as Spy-Bi-Wire (SBW).
- SLAA322** *MSP430 32-kHz Crystal Oscillators.* Selection of the right crystal, correct load circuit, and proper board layout are important for a stable crystal oscillator. This application report summarizes crystal oscillator function and explains the parameters to select the correct crystal for MSP430 ultra-low power operation. In addition, hints and examples for correct board layout are given. The document also contains detailed information on the possible oscillator tests to ensure stable oscillator operation in mass production.
- SLOA089** *Circuit Board Layout Techniques.* Op amp circuitry is analog circuitry and is very different from digital circuitry. It must be partitioned in its own section of the board using special layout techniques. Printed circuit board effects become most apparent in high-speed analog circuits, but common mistakes described in this chapter can even affect the performance of audio circuits. The purpose of this chapter is to discuss some of the more common mistakes made by designers and how they degrade performance, and to provide simple fixes to avoid the problems.
- SLAA530** *MSP430 System-Level ESD Considerations.* System-Level ESD has become increasingly demanding with silicon technology scaling towards lower voltages and the need for designing cost-effective and ultra-low-power components. This application report addresses three different ESD topics to help board designers and OEMs understand and design robust system-level designs.

8.3 Related Links

[Table 8-1](#) lists quick access links. Categories include technical documents, support and community resources, tools and software, and quick access to sample or buy.

Table 8-1. Related Links

PARTS	PRODUCT FOLDER	SAMPLE & BUY	TECHNICAL DOCUMENTS	TOOLS & SOFTWARE	SUPPORT & COMMUNITY
MSP430FR2633	Click here	Click here	Click here	Click here	Click here
MSP430FR2533	Click here	Click here	Click here	Click here	Click here
MSP430FR2632	Click here	Click here	Click here	Click here	Click here
MSP430FR2532	Click here	Click here	Click here	Click here	Click here

8.4 Community Resources

The following links connect to TI community resources. Linked contents are provided "AS IS" by the respective contributors. They do not constitute TI specifications and do not necessarily reflect TI's views; see TI's [Terms of Use](#).

[TI E2E™ Community](#)

TI's Engineer-to-Engineer (E2E) Community. Created to foster collaboration among engineers. At e2e.ti.com, you can ask questions, share knowledge, explore ideas, and help solve problems with fellow engineers.

[TI Embedded Processors Wiki](#)

Texas Instruments Embedded Processors Wiki. Established to help developers get started with embedded processors from Texas Instruments and to foster innovation and growth of general knowledge about the hardware and software surrounding these devices.

8.5 Trademarks

CapTIvate, MSP430, Code Composer Studio, E2E are trademarks of Texas Instruments.

8.6 Electrostatic Discharge Caution



This integrated circuit can be damaged by ESD. Texas Instruments recommends that all integrated circuits be handled with appropriate precautions. Failure to observe proper handling and installation procedures can cause damage.

ESD damage can range from subtle performance degradation to complete device failure. Precision integrated circuits may be more susceptible to damage because very small parametric changes could cause the device not to meet its published specifications.

8.7 Export Control Notice

Recipient agrees to not knowingly export or re-export, directly or indirectly, any product or technical data (as defined by the U.S., EU, and other Export Administration Regulations) including software, or any controlled product restricted by other applicable national regulations, received from disclosing party under nondisclosure obligations (if any), or any direct product of such technology, to any destination to which such export or re-export is restricted or prohibited by U.S. or other applicable laws, without obtaining prior authorization from U.S. Department of Commerce and other competent Government authorities to the extent required by those laws.

8.8 Glossary

[TI Glossary](#) This glossary lists and explains terms, acronyms, and definitions.

9 Mechanical, Packaging, and Orderable Information

The following pages include mechanical, packaging, and orderable information. This information is the most current data available for the designated devices. This data is subject to change without notice and revision of this document. For browser-based versions of this data sheet, see the left-hand navigation.

PACKAGING INFORMATION

Orderable Device	Status (1)	Package Type	Package Drawing	Pins	Package Qty	Eco Plan (2)	Lead/Ball Finish (6)	MSL Peak Temp (3)	Op Temp (°C)	Device Marking (4/5)	Samples
MSP430FR2532IRGER	ACTIVE	VQFN	RGE	24	3000	Green (RoHS & no Sb/Br)	CU NIPDAU	Level-2-260C-1 YEAR	-40 to 85	FR2532	Samples
MSP430FR2532IRGET	ACTIVE	VQFN	RGE	24	250	Green (RoHS & no Sb/Br)	CU NIPDAU	Level-2-260C-1 YEAR	-40 to 85	FR2532	Samples
MSP430FR2533IDA	ACTIVE	TSSOP	DA	32	46	Green (RoHS & no Sb/Br)	CU NIPDAU	Level-2-260C-1 YEAR	-40 to 85	FR2533	Samples
MSP430FR2533IDAR	ACTIVE	TSSOP	DA	32	2000	Green (RoHS & no Sb/Br)	CU NIPDAU	Level-2-260C-1 YEAR	-40 to 85	FR2533	Samples
MSP430FR2533IRHBR	ACTIVE	VQFN	RHB	32	3000	Green (RoHS & no Sb/Br)	CU NIPDAU	Level-3-260C-168 HR	-40 to 85	FR2533	Samples
MSP430FR2533IRHBT	ACTIVE	VQFN	RHB	32	250	Green (RoHS & no Sb/Br)	CU NIPDAU	Level-3-260C-168 HR	-40 to 85	FR2533	Samples
MSP430FR2632IRGER	ACTIVE	VQFN	RGE	24	3000	Green (RoHS & no Sb/Br)	CU NIPDAU	Level-2-260C-1 YEAR	-40 to 85	FR2632	Samples
MSP430FR2632IRGET	ACTIVE	VQFN	RGE	24	250	Green (RoHS & no Sb/Br)	CU NIPDAU	Level-2-260C-1 YEAR	-40 to 85	FR2632	Samples
MSP430FR2633IDA	ACTIVE	TSSOP	DA	32	46	Green (RoHS & no Sb/Br)	CU NIPDAU	Level-2-260C-1 YEAR	-40 to 85	FR2633	Samples
MSP430FR2633IDAR	ACTIVE	TSSOP	DA	32	2000	Green (RoHS & no Sb/Br)	CU NIPDAU	Level-2-260C-1 YEAR	-40 to 85	FR2633	Samples
MSP430FR2633IRHBR	ACTIVE	VQFN	RHB	32	3000	Green (RoHS & no Sb/Br)	CU NIPDAU	Level-3-260C-168 HR	-40 to 85	FR2633	Samples
MSP430FR2633IRHBT	ACTIVE	VQFN	RHB	32	250	Green (RoHS & no Sb/Br)	CU NIPDAU	Level-3-260C-168 HR	-40 to 85	FR2633	Samples

(1) The marketing status values are defined as follows:

ACTIVE: Product device recommended for new designs.

LIFEBUY: TI has announced that the device will be discontinued, and a lifetime-buy period is in effect.

NRND: Not recommended for new designs. Device is in production to support existing customers, but TI does not recommend using this part in a new design.

PREVIEW: Device has been announced but is not in production. Samples may or may not be available.

OBSOLETE: TI has discontinued the production of the device.

(2) Eco Plan - The planned eco-friendly classification: Pb-Free (RoHS), Pb-Free (RoHS Exempt), or Green (RoHS & no Sb/Br) - please check <http://www.ti.com/productcontent> for the latest availability information and additional product content details.

TBD: The Pb-Free/Green conversion plan has not been defined.

Pb-Free (RoHS): TI's terms "Lead-Free" or "Pb-Free" mean semiconductor products that are compatible with the current RoHS requirements for all 6 substances, including the requirement that lead not exceed 0.1% by weight in homogeneous materials. Where designed to be soldered at high temperatures, TI Pb-Free products are suitable for use in specified lead-free processes.

Pb-Free (RoHS Exempt): This component has a RoHS exemption for either 1) lead-based flip-chip solder bumps used between the die and package, or 2) lead-based die adhesive used between the die and leadframe. The component is otherwise considered Pb-Free (RoHS compatible) as defined above.

Green (RoHS & no Sb/Br): TI defines "Green" to mean Pb-Free (RoHS compatible), and free of Bromine (Br) and Antimony (Sb) based flame retardants (Br or Sb do not exceed 0.1% by weight in homogeneous material)

⁽³⁾ MSL, Peak Temp. - The Moisture Sensitivity Level rating according to the JEDEC industry standard classifications, and peak solder temperature.

⁽⁴⁾ There may be additional marking, which relates to the logo, the lot trace code information, or the environmental category on the device.

⁽⁵⁾ Multiple Device Markings will be inside parentheses. Only one Device Marking contained in parentheses and separated by a "~" will appear on a device. If a line is indented then it is a continuation of the previous line and the two combined represent the entire Device Marking for that device.

⁽⁶⁾ Lead/Ball Finish - Orderable Devices may have multiple material finish options. Finish options are separated by a vertical ruled line. Lead/Ball Finish values may wrap to two lines if the finish value exceeds the maximum column width.

Important Information and Disclaimer:The information provided on this page represents TI's knowledge and belief as of the date that it is provided. TI bases its knowledge and belief on information provided by third parties, and makes no representation or warranty as to the accuracy of such information. Efforts are underway to better integrate information from third parties. TI has taken and continues to take reasonable steps to provide representative and accurate information but may not have conducted destructive testing or chemical analysis on incoming materials and chemicals. TI and TI suppliers consider certain information to be proprietary, and thus CAS numbers and other limited information may not be available for release.

In no event shall TI's liability arising out of such information exceed the total purchase price of the TI part(s) at issue in this document sold by TI to Customer on an annual basis.

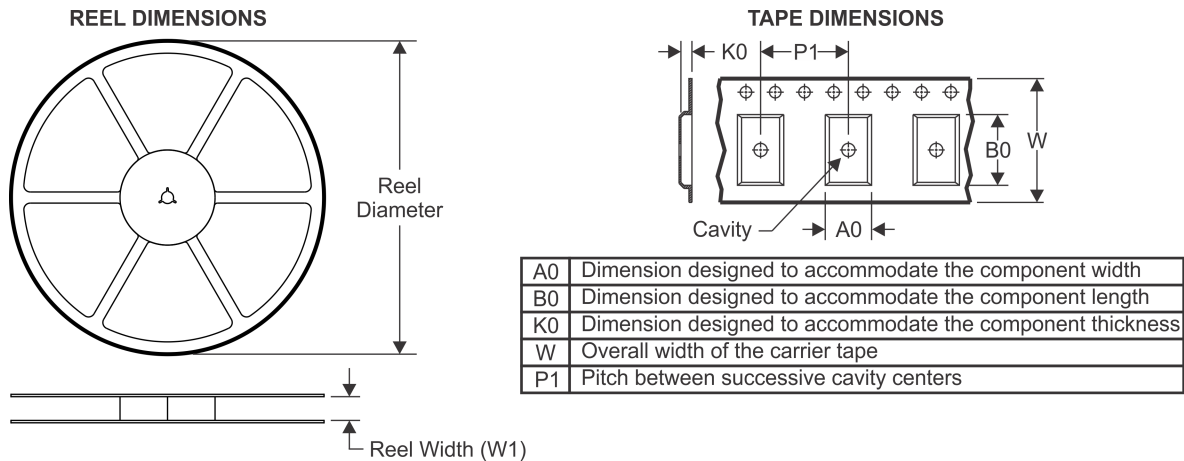
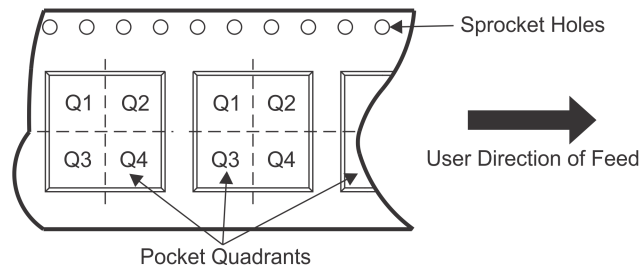
TAPE AND REEL INFORMATION

QUADRANT ASSIGNMENTS FOR PIN 1 ORIENTATION IN TAPE

*All dimensions are nominal

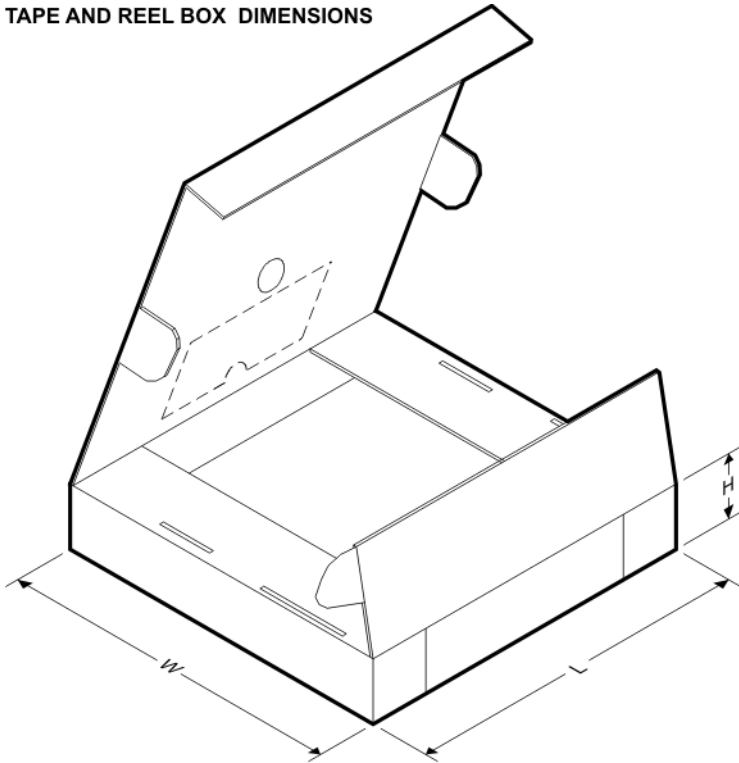
Device	Package Type	Package Drawing	Pins	SPQ	Reel Diameter (mm)	Reel Width W1 (mm)	A0 (mm)	B0 (mm)	K0 (mm)	P1 (mm)	W (mm)	Pin1 Quadrant
MSP430FR2532IRGER	VQFN	RGE	24	3000	330.0	12.4	4.25	4.25	1.15	8.0	12.0	Q2
MSP430FR2533IDAR	TSSOP	DA	32	2000	330.0	24.4	8.6	11.5	1.6	12.0	24.0	Q1
MSP430FR2533IRHBR	VQFN	RHB	32	3000	330.0	12.4	5.3	5.3	1.1	8.0	12.0	Q2
MSP430FR2632IRGER	VQFN	RGE	24	3000	330.0	12.4	4.25	4.25	1.15	8.0	12.0	Q2
MSP430FR2633IDAR	TSSOP	DA	32	2000	330.0	24.4	8.6	11.5	1.6	12.0	24.0	Q1
MSP430FR2633IRHBR	VQFN	RHB	32	3000	330.0	12.4	5.3	5.3	1.1	8.0	12.0	Q2

TAPE AND REEL BOX DIMENSIONS

*All dimensions are nominal

Device	Package Type	Package Drawing	Pins	SPQ	Length (mm)	Width (mm)	Height (mm)
MSP430FR2532IRGER	VQFN	RGE	24	3000	367.0	367.0	35.0
MSP430FR2533IDAR	TSSOP	DA	32	2000	367.0	367.0	45.0
MSP430FR2533IRHBR	VQFN	RHB	32	3000	367.0	367.0	35.0
MSP430FR2632IRGER	VQFN	RGE	24	3000	367.0	367.0	35.0
MSP430FR2633IDAR	TSSOP	DA	32	2000	367.0	367.0	45.0
MSP430FR2633IRHBR	VQFN	RHB	32	3000	367.0	367.0	35.0

IMPORTANT NOTICE

Texas Instruments Incorporated (TI) reserves the right to make corrections, enhancements, improvements and other changes to its semiconductor products and services per JESD46, latest issue, and to discontinue any product or service per JESD48, latest issue. Buyers should obtain the latest relevant information before placing orders and should verify that such information is current and complete.

TI's published terms of sale for semiconductor products (<http://www.ti.com/sc/docs/stdterms.htm>) apply to the sale of packaged integrated circuit products that TI has qualified and released to market. Additional terms may apply to the use or sale of other types of TI products and services.

Reproduction of significant portions of TI information in TI data sheets is permissible only if reproduction is without alteration and is accompanied by all associated warranties, conditions, limitations, and notices. TI is not responsible or liable for such reproduced documentation. Information of third parties may be subject to additional restrictions. Resale of TI products or services with statements different from or beyond the parameters stated by TI for that product or service voids all express and any implied warranties for the associated TI product or service and is an unfair and deceptive business practice. TI is not responsible or liable for any such statements.

Buyers and others who are developing systems that incorporate TI products (collectively, "Designers") understand and agree that Designers remain responsible for using their independent analysis, evaluation and judgment in designing their applications and that Designers have full and exclusive responsibility to assure the safety of Designers' applications and compliance of their applications (and of all TI products used in or for Designers' applications) with all applicable regulations, laws and other applicable requirements. Designer represents that, with respect to their applications, Designer has all the necessary expertise to create and implement safeguards that (1) anticipate dangerous consequences of failures, (2) monitor failures and their consequences, and (3) lessen the likelihood of failures that might cause harm and take appropriate actions. Designer agrees that prior to using or distributing any applications that include TI products, Designer will thoroughly test such applications and the functionality of such TI products as used in such applications.

TI's provision of technical, application or other design advice, quality characterization, reliability data or other services or information, including, but not limited to, reference designs and materials relating to evaluation modules, (collectively, "TI Resources") are intended to assist designers who are developing applications that incorporate TI products; by downloading, accessing or using TI Resources in any way, Designer (individually or, if Designer is acting on behalf of a company, Designer's company) agrees to use any particular TI Resource solely for this purpose and subject to the terms of this Notice.

TI's provision of TI Resources does not expand or otherwise alter TI's applicable published warranties or warranty disclaimers for TI products, and no additional obligations or liabilities arise from TI providing such TI Resources. TI reserves the right to make corrections, enhancements, improvements and other changes to its TI Resources. TI has not conducted any testing other than that specifically described in the published documentation for a particular TI Resource.

Designer is authorized to use, copy and modify any individual TI Resource only in connection with the development of applications that include the TI product(s) identified in such TI Resource. NO OTHER LICENSE, EXPRESS OR IMPLIED, BY ESTOPPEL OR OTHERWISE TO ANY OTHER TI INTELLECTUAL PROPERTY RIGHT, AND NO LICENSE TO ANY TECHNOLOGY OR INTELLECTUAL PROPERTY RIGHT OF TI OR ANY THIRD PARTY IS GRANTED HEREIN, including but not limited to any patent right, copyright, mask work right, or other intellectual property right relating to any combination, machine, or process in which TI products or services are used. Information regarding or referencing third-party products or services does not constitute a license to use such products or services, or a warranty or endorsement thereof. Use of TI Resources may require a license from a third party under the patents or other intellectual property of the third party, or a license from TI under the patents or other intellectual property of TI.

TI RESOURCES ARE PROVIDED "AS IS" AND WITH ALL FAULTS. TI DISCLAIMS ALL OTHER WARRANTIES OR REPRESENTATIONS, EXPRESS OR IMPLIED, REGARDING RESOURCES OR USE THEREOF, INCLUDING BUT NOT LIMITED TO ACCURACY OR COMPLETENESS, TITLE, ANY EPIDEMIC FAILURE WARRANTY AND ANY IMPLIED WARRANTIES OF MERCHANTABILITY, FITNESS FOR A PARTICULAR PURPOSE, AND NON-INFRINGEMENT OF ANY THIRD PARTY INTELLECTUAL PROPERTY RIGHTS. TI SHALL NOT BE LIABLE FOR AND SHALL NOT DEFEND OR INDEMNIFY DESIGNER AGAINST ANY CLAIM, INCLUDING BUT NOT LIMITED TO ANY INFRINGEMENT CLAIM THAT RELATES TO OR IS BASED ON ANY COMBINATION OF PRODUCTS EVEN IF DESCRIBED IN TI RESOURCES OR OTHERWISE. IN NO EVENT SHALL TI BE LIABLE FOR ANY ACTUAL, DIRECT, SPECIAL, COLLATERAL, INDIRECT, PUNITIVE, INCIDENTAL, CONSEQUENTIAL OR EXEMPLARY DAMAGES IN CONNECTION WITH OR ARISING OUT OF TI RESOURCES OR USE THEREOF, AND REGARDLESS OF WHETHER TI HAS BEEN ADVISED OF THE POSSIBILITY OF SUCH DAMAGES.

Unless TI has explicitly designated an individual product as meeting the requirements of a particular industry standard (e.g., ISO/TS 16949 and ISO 26262), TI is not responsible for any failure to meet such industry standard requirements.

Where TI specifically promotes products as facilitating functional safety or as compliant with industry functional safety standards, such products are intended to help enable customers to design and create their own applications that meet applicable functional safety standards and requirements. Using products in an application does not by itself establish any safety features in the application. Designers must ensure compliance with safety-related requirements and standards applicable to their applications. Designer may not use any TI products in life-critical medical equipment unless authorized officers of the parties have executed a special contract specifically governing such use. Life-critical medical equipment is medical equipment where failure of such equipment would cause serious bodily injury or death (e.g., life support, pacemakers, defibrillators, heart pumps, neurostimulators, and implantables). Such equipment includes, without limitation, all medical devices identified by the U.S. Food and Drug Administration as Class III devices and equivalent classifications outside the U.S.

TI may expressly designate certain products as completing a particular qualification (e.g., Q100, Military Grade, or Enhanced Product). Designers agree that it has the necessary expertise to select the product with the appropriate qualification designation for their applications and that proper product selection is at Designers' own risk. Designers are solely responsible for compliance with all legal and regulatory requirements in connection with such selection.

Designer will fully indemnify TI and its representatives against any damages, costs, losses, and/or liabilities arising out of Designer's non-compliance with the terms and provisions of this Notice.